

# *Video Communication System*

---

## **Operating Instructions (Version 2.0)**

Before operating the unit, please read this manual thoroughly and retain it for future reference.

**IPELA****PCS-TL33**

## Owner's Record

The model and the serial numbers are located at the rear. Record the serial number in the space provided below. Refer to these numbers whenever you call upon your Sony dealer regarding this product.

Model No. PCS-TL33 Serial No. \_\_\_\_\_

### WARNING

**To reduce a risk of fire or electric shock, do not expose this product to rain or moisture.**

**To avoid electrical shock, do not open the cabinet. Refer servicing to qualified personnel only.**

### WARNING

Use the AC power adapter provided with this equipment as a power supply source.

Manufacture	Type No.
Sony	VGP-AC19V15

Any other power sources may result in hazards such as a fire. Disconnect device of this equipment is the mains plug of the AC adapter.

The mains plug on this equipment must be used to disconnect mains power.

Please ensure that the socket outlet is installed near the equipment and shall be easily accessible.

In the event of abnormal operations, disconnect the mains plug.

### NOTICE

Use the power cord set approved by the appropriate testing organization for the specific countries where this unit is to be used.

### CAUTION for LAN port

For safety reason, do not connect the LAN port to any network devices that might have excessive voltage.

### For the customers in the USA

### WARNING

This device complies with Part 15 of the FCC Rules. Operation is subject to the following two conditions: (1) This device may not cause harmful interference, and (2) this device must accept any interference received, including interference that may cause undesired operation.

This equipment has been tested and found to comply with the limits for a Class A digital device, pursuant to Part 15 of the FCC Rules. These limits are designed to provide reasonable protection against harmful interference when the equipment is operated in a commercial environment.

This equipment generates, uses, and can radiate radio frequency energy and, if not installed and used in accordance with the instruction manual, may cause harmful interference to radio communications. Operation of this equipment in a residential area is likely to cause harmful interference in which case the user will be required to correct the interference at his own expense.

You are cautioned that any changes or modifications not expressly approved in this manual could void your authority to operate this equipment.

All interface cables used to connect peripherals must be shielded in order to comply with the limits for a computing device pursuant to Subpart B of Part 15 of FCC Rules.

## Disposal of the used lamp

### For the customers in the USA

Lamp in this product contains mercury. Disposal of these materials may be regulated due to environmental considerations. For disposal or recycling information, please contact your local authorities or the Electronic Industries Alliance ([www.eiae.org](http://www.eiae.org)).

### For the customers in Canada

This Class A digital apparatus complies with Canadian ICES-003.

Cet appareil numérique de la classe A est conforme à la norme NMB-003 du Canada.

### For the customers in Europe

The manufacturer of this product is Sony Corporation, 1-7-1 Konan, Minato-ku, Tokyo, Japan.

The Authorized Representative for EMC and product safety is Sony Deutschland GmbH, Hedelfinger Strasse 61, 70327 Stuttgart, Germany. For any service or guarantee matters please refer to the addresses given in separate service or guarantee documents.

### For the customers in Europe, Australia and New Zealand

### WARNING

This is a Class A product. In a domestic environment, this product may cause radio interference in which case the user may be required to take adequate measures. In the case that interference should occur, consult your nearest authorized Sony service facility.

This apparatus shall not be used in the residential area.

---

# Table of Contents

Precautions .....	8
-------------------	---

---

## Chapter 1 Installation and Preparation

<b>Using This Manual .....</b>	<b>9</b>
<b>Features .....</b>	<b>10</b>
<b>System Components .....</b>	<b>11</b>
Basic System Components .....	11
Optional Equipment .....	12
<b>Names and Functions of Parts .....</b>	<b>12</b>
PCS-TL33 Video Communication System .....	12
Indicator Names and Functions .....	14
PCSA-DSM1 Data Solution Module (Optional).....	14
<b>System Connections .....</b>	<b>15</b>
About the Connectors .....	15
Connection Precautions .....	15
System Connection via a LAN .....	15
<b>Adjusting the Height of the Display .....</b>	<b>16</b>
<b>Turning the System On/Off .....</b>	<b>17</b>
Opening the Lens Cover .....	17
Turning the System On.....	17
Turning the System Off .....	18
Setting the Video Communication System to Standby Mode .....	18
Adjusting the Volume .....	18
Adjusting the Picture Quality .....	18
Displaying Help.....	18
Displaying Version and Option Information.....	18
<b>Setting Up the System for the First Time — Initial Setup Wizard .....</b>	<b>19</b>
<b>Using the Menu .....</b>	<b>20</b>
Menu Configurations.....	20
Explanation of Menus .....	21
Entering Characters .....	23

---

## Chapter 2 Registration and Setup

<b>Registering Local Information.....</b>	<b>24</b>
Opening the Setup Menu .....	24
Answer Setup Menu .....	25

Device Setup Menu .....	25
Audio Setup Menu.....	27
Network Setup Menu.....	27
Communication Mode Menu.....	29
Administrator Setup Menu .....	32
Display Setup Menu .....	36
<b>Registering a Remote Party in the Phone Book .....</b>	<b>38</b>
Registering a New Remote Party .....	38
Changing the Contents of the Phone Book .....	39
Deleting a Registered Remote Party .....	39
Copying an Entry in the Phone Book.....	39
Creating a Private Phone Book .....	39
Using the Shared Phone Book.....	41
Checking the History of Outgoing and Incoming Calls .....	42
<b>Registering a Remote Party for One Touch Dial.....</b>	<b>42</b>
One Touch Dial Registration.....	42
Registering the Private One Touch Dial.....	43
<b>Setting Up the Network Configurations.....</b>	<b>43</b>
LAN (Connecting via DHCP) .....	43
LAN (Connecting Through a Router) .....	44
LAN (Connecting Through a Gatekeeper).....	44
LAN (Connecting Through NAT).....	45
LAN (Connecting With H.460 Firewall Traversal) .....	46
LAN (PPPoE Connections) .....	47

---

## Chapter 3 Basic Videoconference

<b>Starting a Conference by Calling a Remote Party .....</b>	<b>48</b>
Turning on the Power .....	48
Using the Launcher Menu .....	49
Using the Communication Screen .....	50
Status & Info Menu .....	51
Calling a Remote Party Using One Touch Dial .....	52
Calling a Remote Party by Entering the IP Address in the Launcher Menu .....	53
Calling a Remote Party Registered in the Phone Book.....	53
Calling a Remote Party From the Incoming/Outgoing Call History...	54
<b>Receiving a Call From a Remote Party .....</b>	<b>55</b>
Answering a Call From a Remote Party.....	55
Ending the Conference .....	55
<b>Joining a Multipoint Videoconference .....</b>	<b>56</b>
<b>Adjusting the Picture and Sound .....</b>	<b>57</b>

Adjusting the Picture Quality .....	57
Adjusting the Volume .....	57
Cutting Off the Sound Momentarily - Mic Off Function .....	57
Cutting Off the Sound On Answering - Mic Off Function .....	57
Synchronizing Audio and Video - Lip Sync Function .....	57
Reducing Echo - Echo Canceller.....	57
<b>Adjusting the Camera.....</b>	<b>58</b>
Adjusting the Zoom and Camera Angle.....	58
Accepting Remote Camera Control .....	59
Adjusting the Brightness .....	59
Presetting the Zoom and Angle Settings .....	60
Recalling a Preset Zoom and Angle Setting.....	60
<b>Changing the Screen Layout .....</b>	<b>61</b>
Bringing up the Screen Layout Setup Menu .....	61
Switching the Display .....	61

---

## Chapter 4 Videoconference With Optional Equipment

<b>Using Still Images Stored in a “Memory Stick” for a Videoconference .....</b>	<b>63</b>
Displaying a Still Image Stored on a “Memory Stick” .....	63
Sending a Still Image Stored on a “Memory Stick”.....	64
<b>About “Memory Stick” .....</b>	<b>65</b>
Formatting a “Memory Stick” .....	66
<b>Sending Motion Pictures as Still Images.....</b>	<b>66</b>
Sending Still Images Using the Still Image Menu .....	66
Receiving Still Images.....	67
Receiving Whiteboard Images .....	67
<b>Saving Still Images .....</b>	<b>68</b>
Saving Remote Party Pictures Automatically – Automatic Image Capture Feature.....	68
Saving Still Images Using the Still Image Menu .....	68
<b>Using External Microphone and Headphones .....</b>	<b>69</b>
<b>Controlling the Remote System With Tone Signals - DTMF Transmission .....</b>	<b>69</b>
<b>Accessing the Video Communication System.....</b>	<b>70</b>
Using the Web Monitor Function.....	70
Using a Web Browser.....	70
Using Telnet .....	70

---

## Chapter 5 Data Conference Using Data Solution Module

<b>Installing the Data Solution Module</b> .....	<b>72</b>
<b>Connection Example Using the Data Solution Module</b> .....	<b>73</b>
<b>Using Video From Connected Equipment for a Conference</b> .....	<b>74</b>
Operating the System During a Conference.....	74

---

## Chapter 6 Encrypted Videoconference via LAN

<b>Preparing for an Encrypted Videoconference via LAN</b> .....	<b>77</b>
<b>Starting an Encrypted Videoconference via LAN</b> .....	<b>79</b>

---

## Chapter 7 Videoconference Using SIP

<b>Connection Examples for a Videoconference Using SIP</b> .....	<b>81</b>
Connection Example for Point-to-Point Videoconference.....	81
<b>Preparing for a Videoconference Using SIP</b> .....	<b>82</b>
Installing the SIP Software.....	82
Making Settings for SIP .....	82
Registering Remote Parties in the Phone Book.....	82
<b>Starting a Videoconference Using SIP</b> .....	<b>83</b>
Calling Remote Parties .....	83
Receiving a Call From a Remote Party .....	83
Putting a Videoconference on Hold .....	84
Transferring a Videoconference .....	84
Ending a Videoconference .....	84

---

## Chapter 8 Use as Computer Display

<b>Using as Computer Display</b> .....	<b>85</b>
Connecting to a Computer.....	85
Separate Mouse .....	86
Shared Mouse .....	86
Displaying the Picture From the Computer.....	87
Displaying the Picture From the Computer During a Videoconference .....	87
<b>Switching Between Videoconference Display and Computer     Display</b> .....	<b>88</b>
<b>Calling a Remote Party or Receiving a Call at the PC Screen</b> ...	<b>89</b>
Calling a Remote Party While PC Screen Is Shown .....	89

Receiving a Call While PC Screen Is Shown.....	89
<b>Adjusting the Picture Quality on the Display .....</b>	<b>89</b>
Display Setup Menu for Videoconference .....	89
Display Setup Menu for the Computer Picture .....	90
Differences in Wide Mode Settings .....	91

---

## Chapter 9 Web Control Function

<b>Open the Web Page .....</b>	<b>92</b>
<b>Identify a User .....</b>	<b>93</b>
<b>How To Use the “Web Control” Window .....</b>	<b>93</b>
<b>Select a Tool.....</b>	<b>94</b>
<b>How To Use “Controller” .....</b>	<b>95</b>
<b>How To Use “Dial/Disconnect” .....</b>	<b>96</b>
<b>How To Use “Phone Book” .....</b>	<b>97</b>
“Phone Book-Edit” Page .....	98
“Phone Book-New” Page .....	99
<b>How To Use “Setup” .....</b>	<b>100</b>
How To Configure KIOSK Mode .....	101
To Display the “Send Message” Page .....	102
To Reset the System .....	103
<b>How To Use “Status &amp; Info” .....</b>	<b>104</b>
To Display the Cause Code List.....	105
To Display the Call Log .....	105
<b>How To Use “Monitor” .....</b>	<b>106</b>

---

## Appendix

<b>Screen Indicators.....</b>	<b>107</b>
<b>On Screen Messages.....</b>	<b>108</b>
<b>Troubleshooting .....</b>	<b>113</b>
<b>Specifications .....</b>	<b>114</b>
Acceptable RGB Input/Output Signals .....	117
Pin Assignment.....	118
Pin Assignment on Optional Board Connectors.....	119
List of Port Numbers Used on the PCS-TL33.....	119
<b>Videoconferencing Room Layout .....</b>	<b>120</b>
<b>Glossary .....</b>	<b>121</b>
<b>Menu Configuration.....</b>	<b>123</b>

---

# Precautions

## Operating or storage location

Avoid operating or storing the system in the following locations:

- Extremely hot or cold places
- Humid or dusty places
- Places exposed to strong vibration
- Close to sources of strong magnetism
- Close to sources of powerful electromagnetic radiation, such as radios or TV transmitters
- Noisy places

## LCD screen

### Notes on use

- Do not expose the LCD screen surface to the sun. Doing so may damage the screen surface.
- Do not push or scratch the LCD screen, or place objects on top of the system. The image may become uneven or the LCD panel may be damaged.
- If the system is used in a cold place, a smear may occur in the picture or the picture may become dark. This does not indicate a failure. These phenomena improve as the temperature rises.
- Ghosting may occur when still pictures are displayed continuously. It may disappear after a few moments.
- The screen and cabinet get warm when the system is in use. This is not a malfunction.

### Display pixels

Although the LCD display panel is made with high-precision technology and has an effective picture element ratio of over 99.99%, black dots (dead pixels) may appear on the screen or pixels may become permanently lit (red, blue, green, etc.) or unlit. The appearance of dead pixels after extended periods of use is common among LCD display panels. Be aware that such appearances do not represent a malfunction.

## Phenomena specific to CMOS sensors

The following phenomena that may appear in images are specific to CMOS (Complementary Metal Oxide Semiconductor) sensors. They do not indicate malfunctions.

### White flecks

Although the CMOS sensors are produced with high-precision technologies, fine white flecks may be generated on the screen in rare cases, caused by cosmic rays, etc. This is related to the principle of CMOS sensors and is not a malfunction.

The white flecks especially tend to be seen in the following cases:

- when operating at a high environmental temperature
- when you have raised the gain (sensitivity)

### Aliasing

When fine patterns, stripes, or lines are shot, they may appear jagged or flicker.

### Note on laser beams

Laser beams may damage a CMOS sensor. You are cautioned that the surface of a CMOS sensor should not be exposed to laser beam radiation in an environment where a laser beam device is used.

## Built-in speakers

The speakers generate magnetism. To avoid damaging the data, keep magnetic tapes and disks away from the speakers.

## Cleaning

- Before cleaning, disconnect the power cord from the AC outlet.
- The LCD screen surface is finished with a special coating. To remove dust from the screen surface, wipe gently with a soft, dry cloth.
- Do not use volatile solvents such as alcohol, benzene or thinners as they may damage the surface finishes.
- When you use chemical cleaning cloth, observe the instructions that come with it.
- Do not apply volatile solvents such as an insecticide to the screen, or allow rubber or plastic objects to touch to the screen for a long time, as they may damage the surface finishes.



---

## Using This Manual

The chapters cover the following contents; please read the chapters that may be required for your type of videoconference.

### **Chapter 1: Installation and Preparation**

This chapter guides you through the system configuration and information required to use your Video Communication System for the first time. It shows you how to install and connect your Video Communication System, to turn the system on/off and how to access basic on-screen menus.

### **Chapter 2: Registration and Setup**

This chapter describes how to register and set up all the necessary items for system administrators, using the on-screen menus.

### **Chapter 3: Basic Videoconference**

This chapter guides you through the basic operations and settings to conduct a videoconference. You will learn how to conduct a conference from start to finish. It is recommended that this chapter be read by participants in the videoconference.

### **Chapter 4: Videoconference With Optional Equipment**

This chapter shows advanced videoconferencing using the optional equipment.

### **Chapter 5: Data Conference Using Data Solution Module**

This chapter shows you how to integrate data from a computer or other external equipment into a videoconference by using the optional Data Solution Module.

### **Chapter 6: Encrypted Videoconference via LAN**

This chapter shows you how to conduct a videoconference using the encryption function for video, audio, and computer data.

### **Chapter 7: Videoconference Using SIP**

This chapter guides you how to conduct a videoconference using SIP with an IP phone, etc. Installing the optional SIP software is required for a session using SIP.

### **Chapter 8: Use as Computer Display**

This chapter shows you how to use the Video Communication System as a computer display.

### **Chapter 9: Web Control Function**

This chapter shows you how to control and set up the PCS-TL33 through the Web.

### **Appendix**

This chapter contains message and troubleshooting lists, specifications, and glossaries.

# Features

The PCS-TL33 Video Communication System is a videoconferencing system that allows natural, face-to-face communications with a remote party by transmitting and receiving images and sound via a LAN (Local Area Network).

## Integrated portable Video Communication System

All necessary elements of the system such as 17-type wide-format display, camera equipped with digital pan/tilt and zoom, codec, microphones and speakers are integrated in a single compact cabinet for easy portability. The integrated design plus VESA mount capability makes it possible to set up a videoconference almost anywhere.

## Up to 30 One Touch Dial entries

Remote parties to which you frequently connect can be registered in the launcher menu. You can then establish a connection simply by clicking a Dial button.

## Supports worldwide standards

Full compliance with the ITU-T Recommendations defined by the WTSC (World Telecommunications Standardization Committee) assures easy connection with remote parties in any country.

## Supports data conferences

Use of the optional PCSA-DSM1 Data Solution Module allows the data from a computer to be incorporated in the presentation or to be shown using a projector.

## High transmission speeds and high-quality picture

The Video Communication System can handle LAN bandwidths of up to 2048 kbps.

## Support for a wide range of video/audio compression formats

The Video Communication System supports H.264, MPEG4, H.263+, H.263, and H.261 for video compression, and MPEG4 Audio, G.722, G.729, G.728, and G.711 for audio compression.

## QoS (Quality of Service) function for optimization of bandwidth and traffic packet through network

“Packet Resend Request” and “Adaptive Rate Control” functions incorporated, allowing solution for busy network traffic or packet loss, which provides consistent high-quality communication.

## Easy setup and operation

The Help menu appears on the display for guidance of operation. The menus used for the system administrator or those for conference participants are separately displayed.

## Memory Stick slot equipped

The Video Communication System is equipped with a Memory Stick slot, allowing the use of still images recorded with a digital still camera and stored in the “Memory Stick”.

You can create your own phone book and One Touch Dial icons in a “Memory Stick” as your private phone book. The PCS-TL33 features “Memory Stick PRO”.

## Supports an encrypted videoconference

You can configure the Video Communication System so that you can start a videoconference only with the terminals that enter the preset password. This feature allows you to hold a strictly confidential videoconference. Encrypted conferences among multiple points or with cascade connection are also available.

## Supports a conference using SIP

Installing the optional PCSA-SP1 SIP software allows conduct of a conference with an IP phone, etc. using SIP (Session Initiation Protocol).

## Use as computer display

The display of the Video Communication System can also be used as a computer display.

If you receive a call from a remote party, the picture of the remote party can be automatically displayed even while you are using the system as a computer display.

## Automatic and manual image capturing

During point-to-point communication, several still images of the remote party are automatically captured and saved in the memory of the Video Communication System. You can use these images for your Phone Book.

If a “Memory Stick” is inserted, you can manually capture a still image of the remote party during communication by pressing the IMAGE CAPTURE button. The manually captured image can also be used for the Phone Book.

## KIOSK Mode available



You can simplify operations and make calling with One Touch Dial the only available operation.

# System Components

The PCS-TL33 Video Communication System is composed of basic system components for a basic videoconference, and optional equipment for an enhanced videoconference.

## Basic System Components

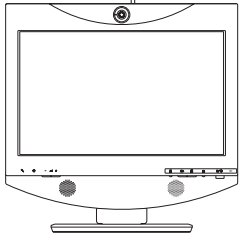
The PCS-TL33 Video Communication System is the basic system of the Videoconferencing System. It contains the following components:

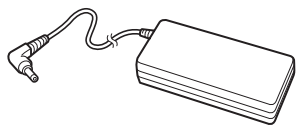
Unit	Description
PCS-TL33 Video Communication System 	Contains the camera, display, video codec, audio codec, echo canceller, network interfaces and system controller.
Optical mouse PCS-RMU1 	Serves for operation of the Video Communication System.  <b>Note</b> Due to the nature of the optical sensor, the mouse may not operate properly on transparent or reflective surfaces (such as glass or mirrors). If the mouse does not operate properly, avoid using these surfaces or use a commercially available optical mouse pad. Depending on the color and material of the mouse pad, however, the mouse may still not operate properly.
VGP-AC19V15 AC adaptor 	Supplies power to the Video Communication System.

.....  
 “IPELA” and IPELA are trademarks of Sony Corporation.

## Optional Equipment

The following optional devices are used to enhance your videoconference.

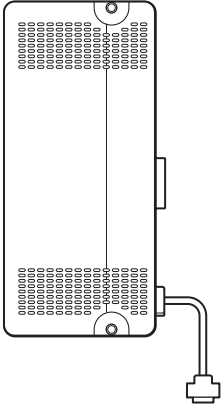
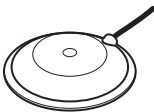
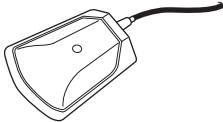
Unit	Description
Data Solution Module PCSA-DSM1 	Serves for transmitting the display image of a connected computer and also allows connection of a projector for displaying the computer image.
PCSA-A1 Microphone 	Omni-directional microphone that picks up sound relatively from all directions, allowing participants to speak from any location. It is recommended to use in a quiet situation.
PCSA-A3 Microphone 	Unidirectional microphone. It is recommended when you want to pick up the voice of a speaker directed toward the microphone.
PCSA-SP1 SIP Software	Allows conduct of a videoconference using SIP.

## Names and Functions of Parts

### PCS-TL33 Video Communication System

#### Front view

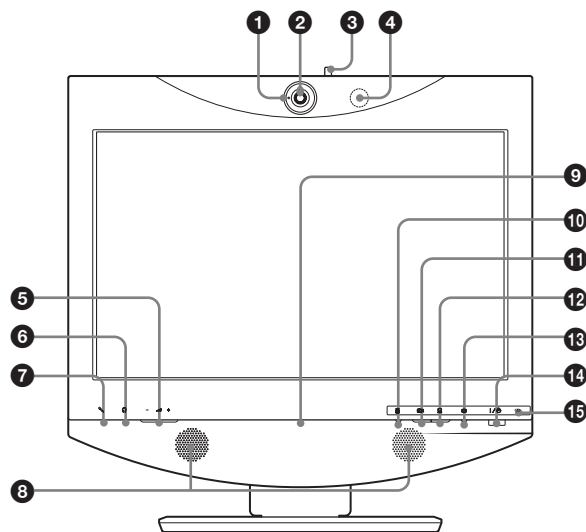

- 1 Tally lamp**  
Lights up when local video is being sent to the remote system.
- 2 Camera lens**
- 3 Lever for lens cover**  
Lets you close the camera lens.
- 4 Microphone**
- 5  $\triangleleft$  (Volume) buttons**  
Serve to adjust the volume.  
+: Increases the volume level.  
-: Decreases the volume level.
- 6  $\Omega$  (Phones) jack (stereo mini jack)**  
Allows connection of a pair of headphones (commercially available).
- 7  $\sphericalangle$  (Mic) jack (mini jack)**  
Allows connection of the optional microphone PCS-A1 or PCSA-A3.
- 8 Speakers**

**9 Online lamp**

Shows mainly the incoming/outgoing call status.

**10 (Mic Off) button and indicator**

Lets you suppress the sound from the local system. Press the button again to resume sending the sound to the remote system.

**11 (Videoconference) button and indicator**

Serves for switching from computer screen to videoconference screen.

**12 (PC) button and indicator**

Serves for switching to computer screen.

**13 (Menu) button**

Press to bring up the Setup menu.

Press and hold this button for 3 seconds during communication to bring up the DTMF soft keyboard on the screen.

**14 (Power) switch and indicator**

Turns power to the system on and off.

When using the system as a computer screen in PC mode, pressing the switch once turns the power off.

When using the system in videoconference mode, pressing the switch once sets the system to standby mode. To turn the power off in videoconference mode, press the switch again within 5 seconds of the first press.

**Note**

The power switch does not function during a communication session.

**15 (Memory Stick) indicator**

Shows the status of the “Memory Stick” slot.

**Note**

Do not remove the “Memory Stick” when this indicator is lit.

**Rear view**

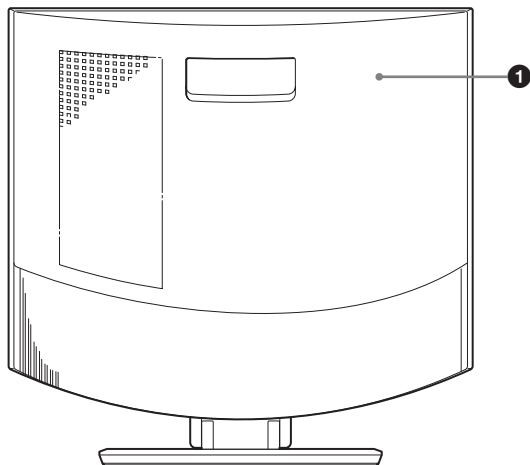

**1 Rear cover**

Removing this cover gives access to the connector panel. The connecting section between the stand and the display is also located behind the panel. You can adjust the height of the display by changing the screw positions.

**Right side view**

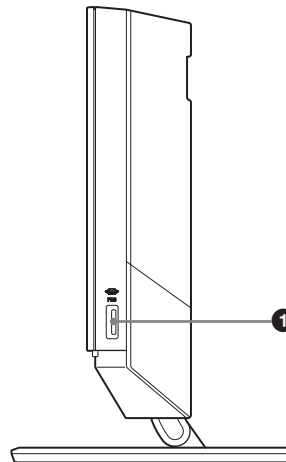

**1 “Memory Stick” slot**

A “Memory Stick” can be inserted here.

**Connector panel (section behind rear cover, seen from below)**

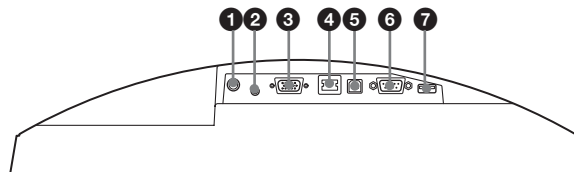

**1 DC19.5V connector**

Connect the supplied AC adapter VGP-AC19V15 here.

**2 AUDIO IN (PC sound input) jack (stereo mini jack)**

Connect this jack to the audio output of a computer connected to the RGB IN connector.

**3 RGB IN connector (15-pin mini D-sub connector)**

Connect the RGB output of a computer here.

**4 100BASE-TX/10BASE-T port (modular port)**

Use a Category 5 LAN cable to connect this port to a hub or similar equipment.

This port is equipped with a Link/Data indicator (green) and a 100/10 Mbps indicator (orange).

**5 PC port**

This connector is used when the same mouse is to be used for the PCS-TL33 and for a computer connected to the RGB IN connector. Link the connector to a USB port on the computer.

**Note**

Use a USB cable that is 3 m (10 ft.) or shorter.

**6 RS-232C port (9-pin D-sub connector)**

This connector is used only for servicing the system.

**7 Mouse port**

Connect the supplied optical mouse PCS-RMU1 here.

**Indicator Names and Functions**

Indicator	Status	Meaning
/ ⏻ (Power) *	Lit green	Power is on
	Lit orange	Standby
	Flashing orange (1-second cycle)	Problem with fan
	Out	Power is off
Online *	Flashing blue (3 times per sec.)	Sending/receiving
	Blue illumination lit	Communication in progress
	Out	Offline (no missed call) or standby
🖥️ (PC) *	Lit blue	Computer display
	Lit white	Videoconference display
	Out	Standby
📺 (Videoconference) *	Lit blue	Videoconference display
	Lit white	Computer display
	Out	Standby
🔊 (Mic off) *	Lit orange	Mic off
	Lit white	Mic on
	Out	Standby
📀 ("Memory Stick")	Lit orange	Accessing "Memory Stick"
	Out	Not accessing "Memory Stick"
Tally lamp	Lit orange	Camera image being sent to remote party (lens cover open)
	Flashing orange (5-second cycle)	Closed image being sent to remote party (lens cover close)
	Out	Camera image not being sent
Link/Data	Lit green	Link is established
	Flashing green	Data is transferring
	Out	Link is offline

Indicator	Status	Meaning
100/10 Mbps	Lit orange	100 Mbps
	Out	10 Mbps

\* The indicator is lit while the system is starting up. If abnormal temperature is detected, the indicator flashes and power turns off.

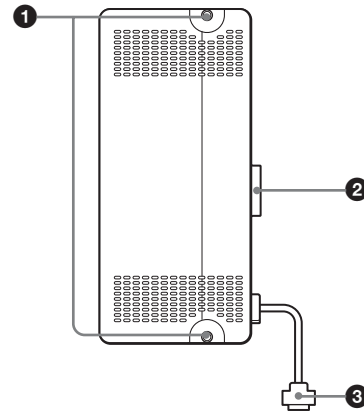
**PCSA-DSM1 Data Solution Module (Optional)****1 Fastening screws**

Used to secure the unit to the PCS-TL33.

**2 Monitor connector**

Used to connect the unit to the PCS-TL33.

**3 RGB Output connector**

Used to connect the unit to an external device, such as a projector.

A commercially available RGB cable is required to use this connector.

*For information about installation in the PCS-TL33, see "Installing the Data Solution Module" on page 72.*



## Adjusting the Height of the Display

The stand and the display section of the PCS-TL33 are joined by fastening screws. There are three sets of screw holes, spaced 25 mm apart. In the factory default condition, the display is fixed in the lowest position. By choosing a different set of screw holes, you can change the height of the display.

- 1 Remove the rear cover of the unit.

*For information on how to do this, see page 15.*

- 2 Remove the 4 screws using a coin or similar object, lift up the stand, and insert the positioning pin in the hole for the new stand position.

### Note

Before changing the height of the display as described above, be sure to turn the power off. Place the display face down on a soft cloth or similar.

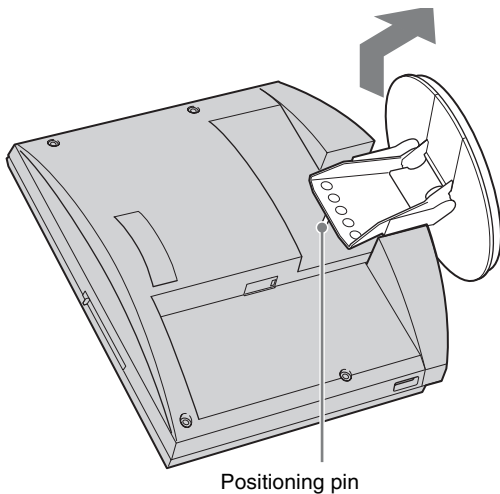
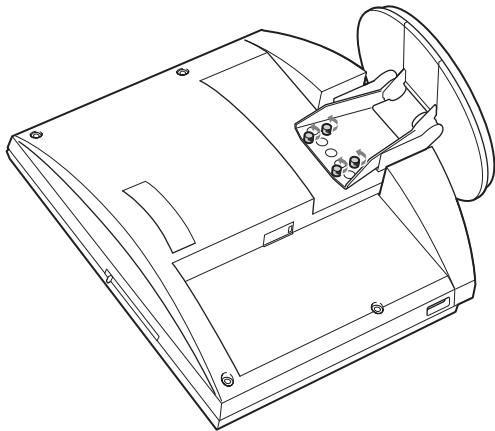

- 3 Tighten the 4 screws using a coin or a similar object to secure the stand.

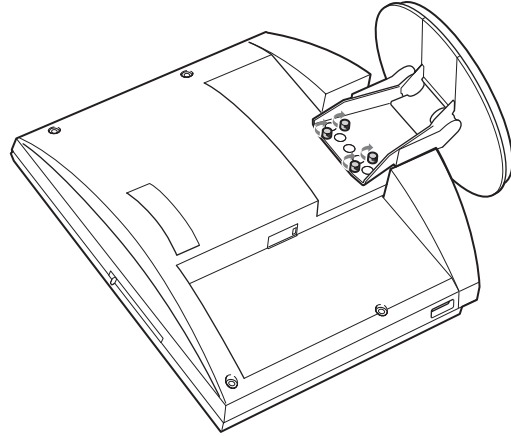

- 4 Attach the rear cover again.



# Turning the System On/Off

This section describes how to turn the Video Communication System on and off. Before turning the system on, make sure that system connections have been completed correctly.

For information on connecting the system, see the section “System Connections” on page 15.

## Opening the Lens Cover

The system is equipped with a lens cover to hide the camera. Before starting a videoconference, open the lens cover by sliding the lever for lens cover on the top of the system to the right. If the lens cover is closed, the picture on the local site will not be seen on the remote site.

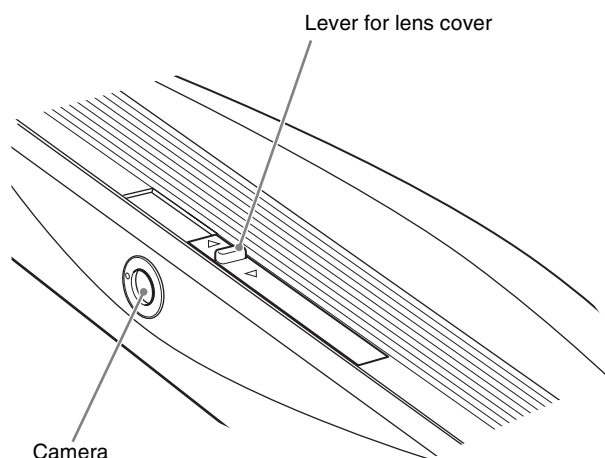

## Turning the System On

Press the  $I/O$  (Power) switch on the PCS-TL33.

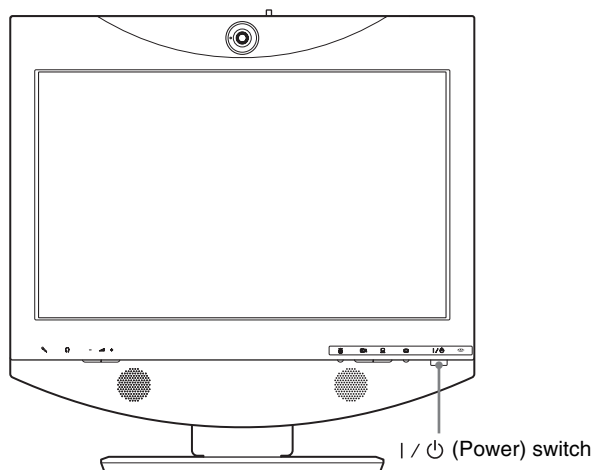

The indicator of the switch lights up in orange and power to the Video Communication System comes on. When powering on is complete, the indicator lights up in green. The launcher menu appears on the display and the picture of the local camera is also shown.

## Launcher menu

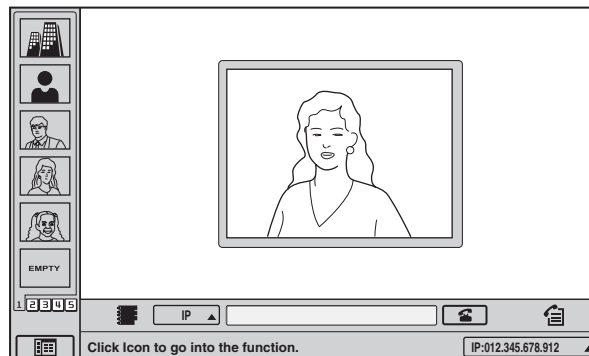

When the lens cover is closed, the launcher menu appears as follows.

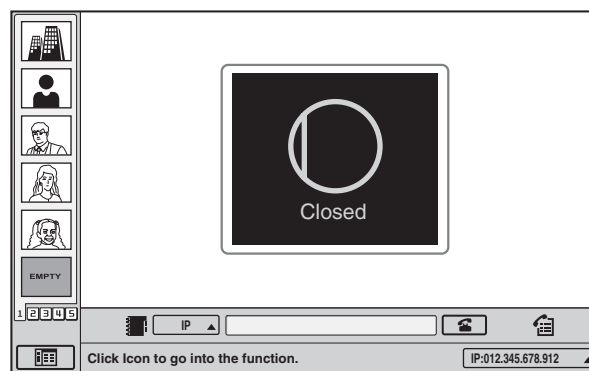

## Notes

- The first time the power switch is pressed after the power cord is plugged into a wall outlet, it may take as long as ten seconds for the indicator on the switch to light up.
- When you turn on power to the Video Communication System for the first time after installation, the setup wizard will appear. Set up your system following the wizard.

For information on the setup procedure using the wizard, see “Setting Up the System for the First Time — Initial Setup Wizard” on page 19.

- When an optional device especially designed for use with this system, such as the Data Solution Module, is connected for the first time, the Video Communication System may automatically upgrade the software of the connected device. While the upgrading message is displayed, be sure not to turn off the Video Communication System. Doing so may cause malfunction of the system. System malfunction may also occur when a system power-off has been caused by an

accidental problem such as a power interruption during upgrading. If the Data Solution Module or other equipment is not recognized properly after power is restored, consult a Sony dealer.

---

## Turning the System Off

### 1 Press the $\text{I} / \text{O}$ (Power) switch twice.

After pressing the switch once, the message “To enter standby mode, wait for a few moments. To turn off the power, press the power switch again.” appears. Press the power switch again.

### 2 Turn off the power of other equipment used for the videoconference.

#### Notes

- Turn the power to the system off when the system will not be used for an extended period. While the power is off, you cannot receive a call from a remote party.
- When using the system as a computer display in PC mode, the power turns off with one press of the power switch.
- During a conference, the power switch does not function.

---

## Setting the Video Communication System to Standby Mode

When you press the  $\text{I} / \text{O}$  (Power) switch on the PCS-TL33, the message “To enter standby mode, wait for a few moments. To turn off the power, press the power switch again.” appears on the display. If you do not click the “Cancel” button, the system will go into standby mode.

You can receive a call from a remote party in the standby mode.

To return to normal mode from standby mode, press the power switch once.

---

## Adjusting the Volume

Press the  $\triangle$  (Volume) button on the PCS-TL33 to set the volume level as required.

#### Note

The volume can be adjusted separately for the videoconference and for the computer display.

---

## Adjusting the Picture Quality

Use the Display Setup menu to adjust the picture quality.

*For details, see the section “Adjusting the Picture Quality on the Display” on page 89.*

---

## Displaying Help

Move the mouse cursor to the item you want to check, and right-click the mouse to display context-specific help window.

---

## Displaying Version and Option Information

You can check version information for Video Communication System, any dedicated optional equipment, and the software by displaying the Status & Info menu.

*For details on the Status & Info menu, see “Status & Info Menu” on page 51.*

# Setting Up the System for the First Time — Initial Setup Wizard

Design and specifications are subject to change without notice.

When you turn on the Video Communication System for the first time after installation, the setup wizard appears on the display.

The items configured with the wizard can be changed later using the setup menu.

Configuration items may differ depending on the software.

- 1 Select the language used for menus and messages from the “Language” pull-down list.

**Language:** Available settings are English, Finnish, French, German, Italian, Japanese, Korean, Portuguese, Russian, Simplified Chinese, Spanish, Swedish, Thai, and Traditional Chinese.

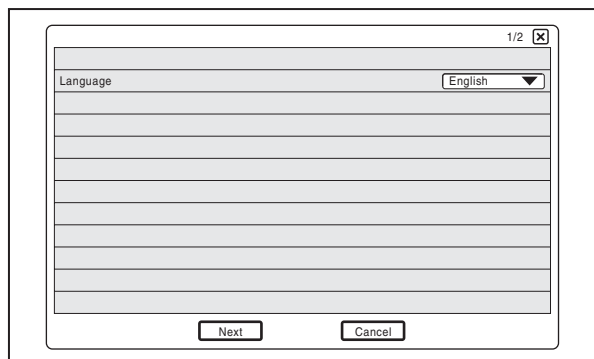

- 2 Click “Next”.
- 3 Make the following settings for the LAN.

### Note

The following examples assume that English has been selected as display language.

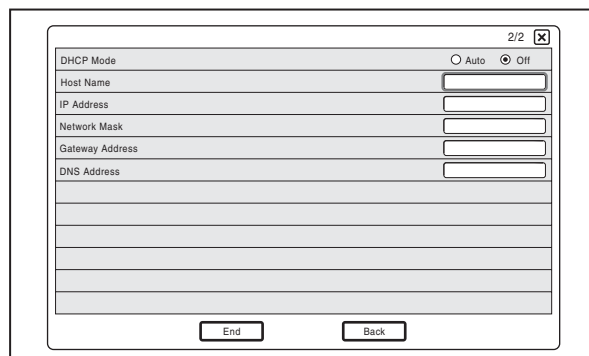

**DHCP Mode:** Sets the DHCP (Dynamic Host Configuration Protocol).

**Auto:** Automatically assigns your IP address, subnet mask, gateway address and DNS address.

**Off:** Deactivates DHCP. In this case you must set your IP address, subnet mask, gateway address and DNS address manually.

**Host Name:** Enter your host name.

**IP Address:** Enter your IP address.

**Network Mask:** Enter your subnet mask.

**Gateway Address:** Enter your default gateway address.

**DNS Address:** Enter your DNS (Domain Name System) server address.

### Note

When you set “DHCP Mode” to “Auto”, the assigned IP address will be shown in the launcher menu (page 21) and Status & Info menu (page 51).

*If you do not know the settings required for your LAN configuration, contact your network administrator.*

- 4 Click “End”.

The settings are saved.

### To cancel the setting

Click “Cancel”.

The settings are not saved and the launcher menu appears.

### To go back to the previous wizard

Click “Back”.

# Using the Menu

The Video Communication System uses the on-screen menus to make various adjustments and settings. This section gives a brief introduction of the menus.





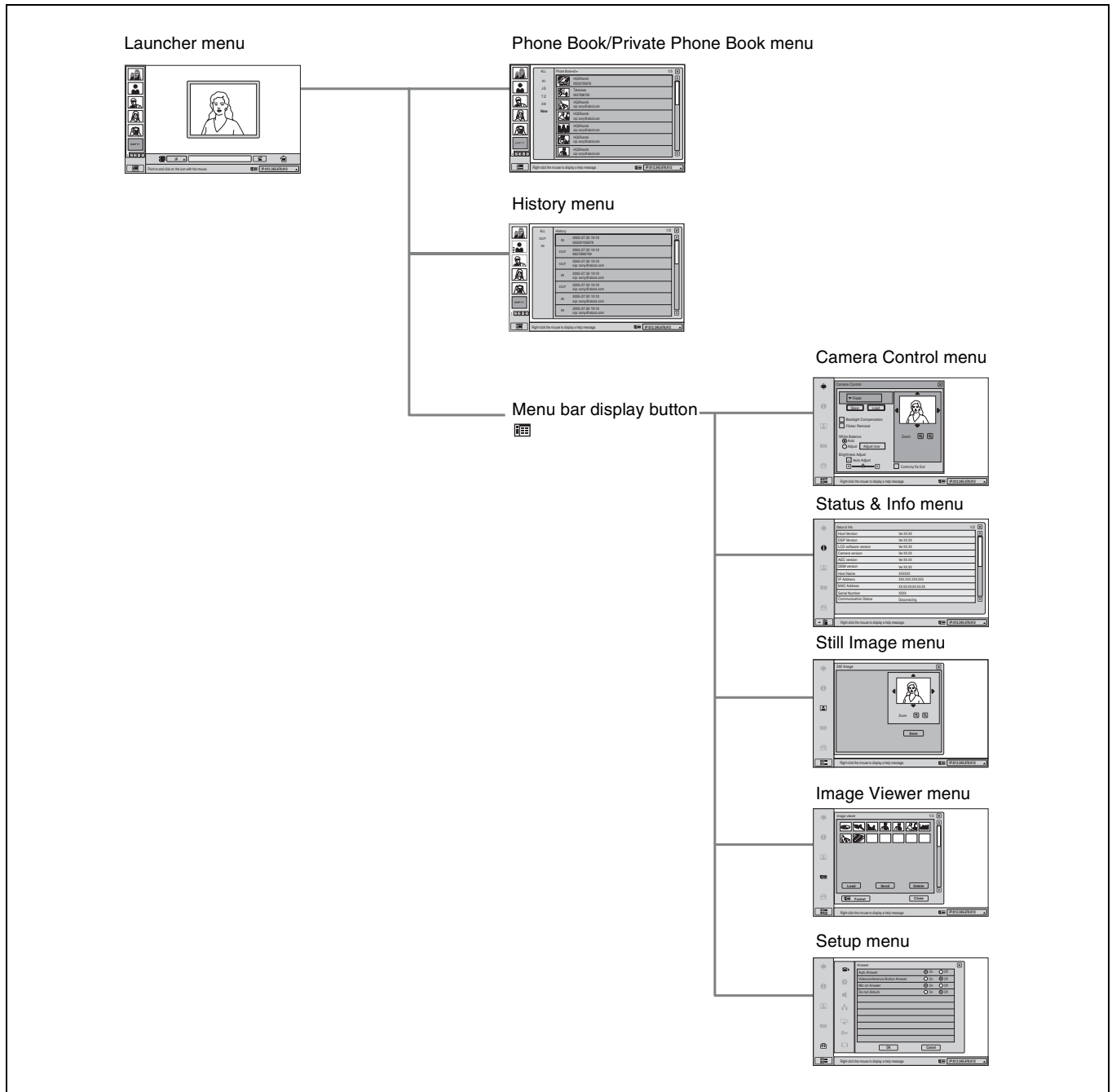



## Menu Configurations

The menus of this system configure as described below. For more detailed menu configurations, refer to “Menu Configuration” on page 123.



## Menu Icons

Selecting an icon shown on the screen displays the respective menu.

Icon	Displayed menu
	Phone Book menu
	Private Phone Book menu
	History menu
	Camera Control menu
	Status & Info menu
	Still Image menu
	Image Viewer menu
	Setup menu

## Explanation of Menus

### Launcher menu

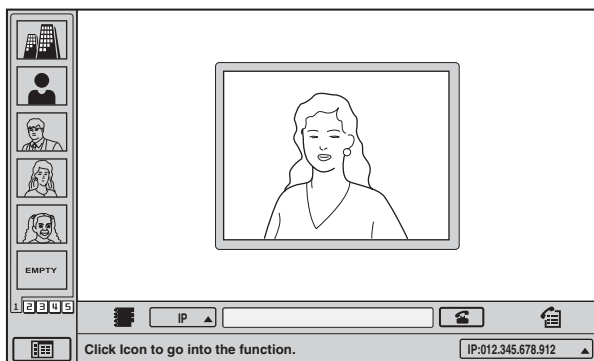

The launcher menu appears when the Video Communication System is turned on, and when the system is not connected to a remote party.

The left side of the screen displays the One Touch Dial buttons, which give access to the One Touch Dial function, and the Menu Bar display button.

*For details on the launcher menu, see pages 49 - 53.*

*For details on the One Touch Dial function, see pages 42 and 52.*

### Phone Book menu

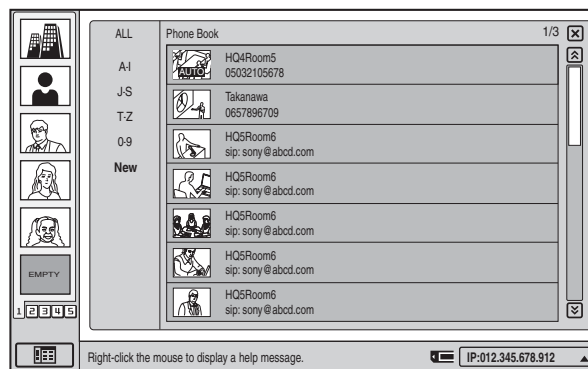



The Phone Book menu is used to register a remote party, and to call a registered remote party.

The menu appears when you click  in the launcher menu.

*For details on the Phone Book menu, see pages 38 - 42 and 53 - 54.*

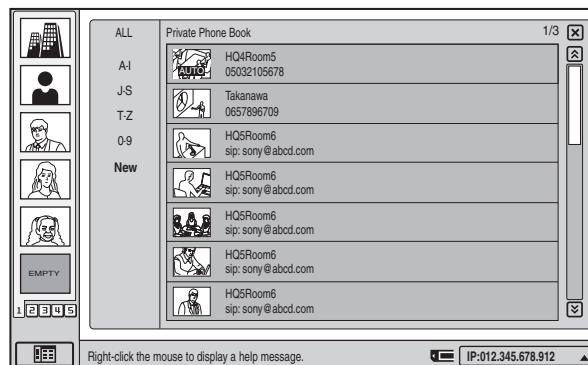
### Private Phone Book menu



The Private Phone Book menu can be used when a “Memory Stick” with a personal (private) phone book saved on to it is inserted into the memory stick slot. The menu appears when you click  in the launcher menu.

*For details on the Private Phone Book menu, see pages 39 - 40, 53 and 54.*

## History menu

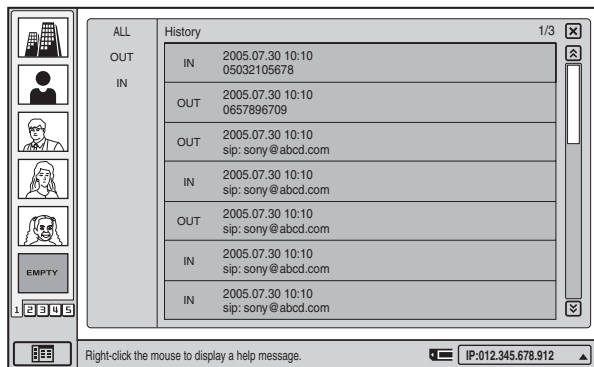



Serves for checking the transmission history of incoming and outgoing calls.

To bring up the menu, click  in the launcher menu.

*For details on the History menu, see page 42.*

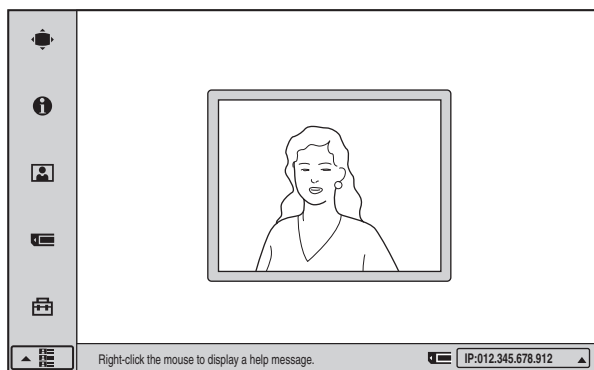
## Settings menu selection screen



Allows you to access menus for various settings. The settings menu bar appears when you click  (menu bar display) in the bottom left of the launcher screen.

## Camera Control menu

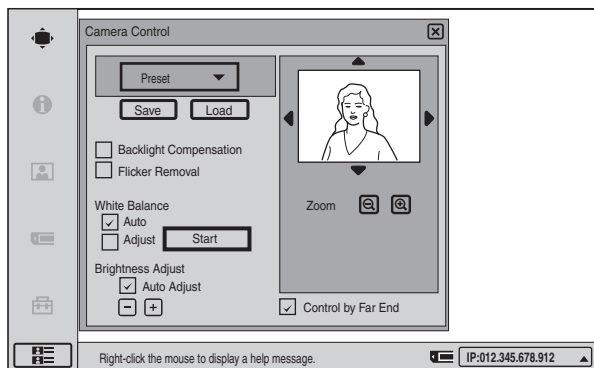

Allows you to control the camera angle and zoom.

The menu appears when you click “Camera Control” on the menu selection screen.

*For details on the Camera Control menu, see pages 58 - 60.*

## Status & Info menu

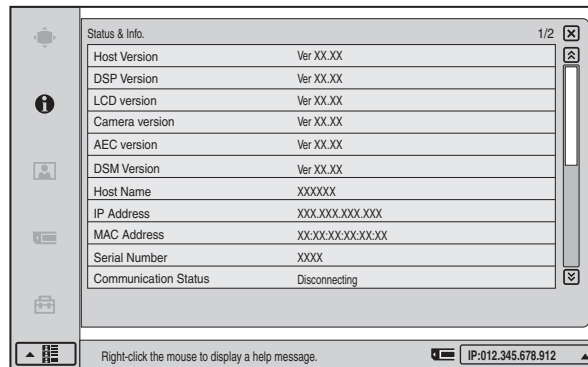

Shows version information about the PCS-TL33 and connected dedicated optional equipment, as well as for the software options being used.

The menu appears when you click “Status & Info” on the menu selection screen.

*For details on the Status & Info menu, see page 51.*

## Still Image menu

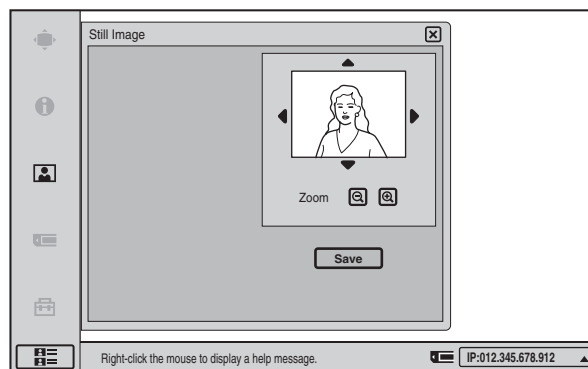

Serves to control the still image functions.

The menu appears when you click “Still Image” on the menu selection screen.

*For details on the Still Image menu, see pages 66 - 68.*

## Image Viewer menu

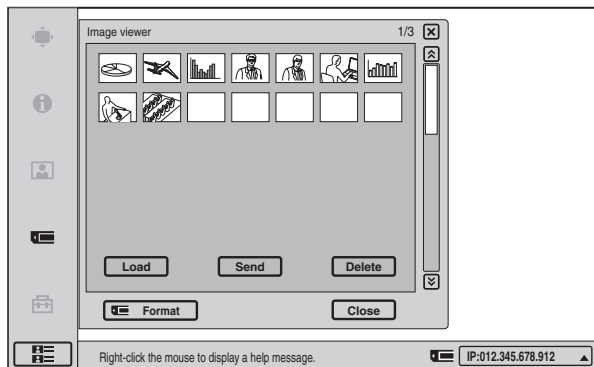

Allows you to display and transmit images stored on a “Memory Stick”.

The menu appears when you click “Image Viewer” on the menu selection screen.

*For details on the Image Viewer menu, see pages 63 - 64.*

## Setup menu

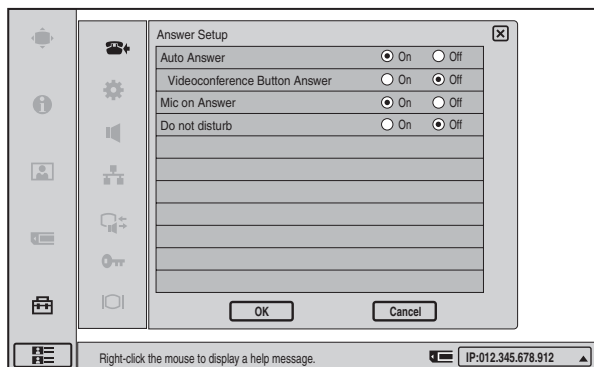

Allows the administrator to make various detailed settings for the system.

The menu appears when you click “Setup” on the menu selection screen.

*For details on the Setup menu, see pages 24 - 37.*

## Entering Characters

This section explains how to enter letters, numerals or symbols into the text fields in the menu using the soft keyboard.

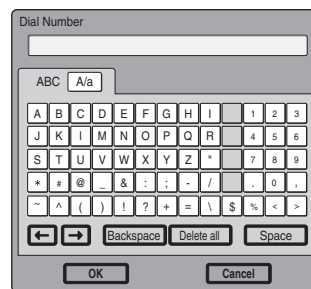

In situations where alphanumeric text input is required, for example when a text field in a menu is selected, a soft keyboard appears. If only numerals and symbols can be entered, a numeric keypad appears.

### To enter alphanumeric characters and symbols

Click the “ABC” tab on the soft keyboard and click on the character or symbol to enter. The “A/a” button toggles between upper and lower case.

### To confirm the alphanumeric characters and symbols entered

After clicking the alphanumeric characters and symbols you wish to enter, click “OK”. The entry is set, and the soft keyboard closes.

### If you have made a mistake

Click the “Backspace” button on the soft keyboard, and the character or symbol before the cursor will be erased. If you click “Delete all”, all the characters and symbols will be erased.

This chapter describes the general registration and settings procedures.

## Registering Local Information

Before starting a conference, register the required information on the local terminals of the system using the Setup menu. This section describes how to display the Setup menus and gives a introduction to the menus.

### Opening the Setup Menu

**1** Click  (menu bar display) on the launcher menu.

The menu bar appears.





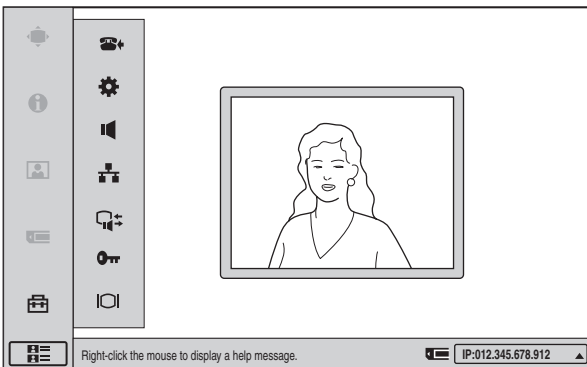

**2** Click “Setup” on the menu bar.

The Setup menu appears.



### Submenus available from the Setup menu

Selecting the respective item brings up the following menus.

Icon	Displayed menu
	Answer Setup menu (page 25)
	Device Setup menu (page 25)
	Audio Setup menu (page 27)
	Network Setup menu (page 27)
	Communication Mode menu (page 29)
	Administrator Setup menu (pages 32)
	Display Setup menu (page 36)

**3** Click the button for the menu you want to access.

The selected menu appears.

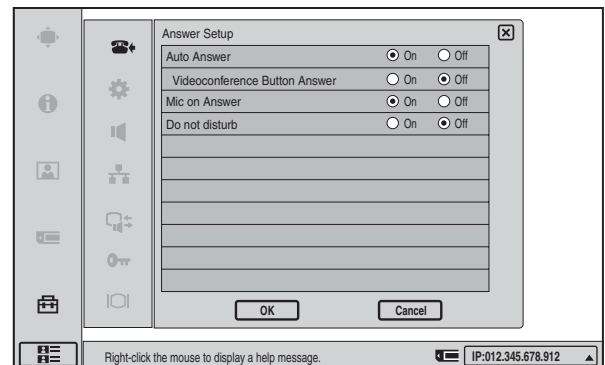

**4** Set the respective items.

*For details on setting items, see the page for the respective menu (pages 25 - 37).*

**5** When the setting is completed, click “OK”.

The setting is saved, and the Setup menu appears again.

### To cancel the setup procedure

Click “Cancel”.



## To page up or down the selected menu

When a menu has several pages, a scroll bar will appear at the right side of the screen. To advance to the next page, click the Page button at the bottom of the scroll bar. To go back to the previous page, click the Page button at the top of the scroll bar. You can also drag the scroll bar up and down using the mouse to scroll through the pages.

## Answer Setup Menu

The Answer Setup menu is used to set the system up for receiving a call.

### Page 1/1

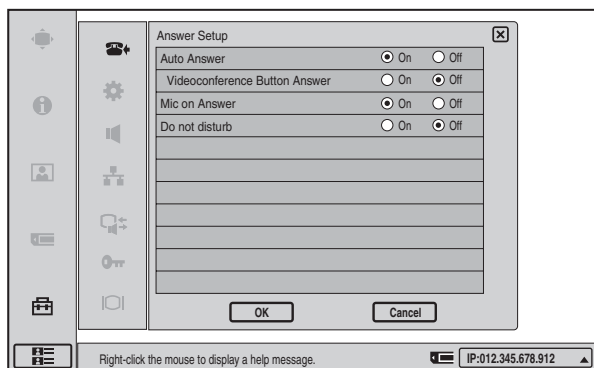



### Auto Answer

Select whether the auto answer mode is activated.

**On:** Answers a call in auto answer mode. When a call comes in and the phone rings, the line is automatically connected.

**Off:** Answers a call in manual answer mode. When you are called up, the phone rings. If you click “OK” when the message “Incoming call. Answer?” is shown, the line is connected.

### Videoconference Button Answer

Select whether to enable call answering with the  (Videoconference) button and call rejection with the  (PC) button when Auto Answer is disabled.

**On:** Enables answer operations with the buttons on the unit.

**Off:** Disables answer operations with the buttons on the unit.

### Mic on Answer

Select whether to transmit the sound on your site when answering a call from the remote party.

**On:** Transmits the sound when answering a call.

**Off:** Disables transmission of the sound when answering a call.

### Do not disturb

Select whether to reject all calls.

**On:** Reject all incoming calls.

**Off:** Do not reject incoming calls.

## Device Setup Menu

### Page 1/2

#### Note

Some items cannot be set while a communication session is in progress.

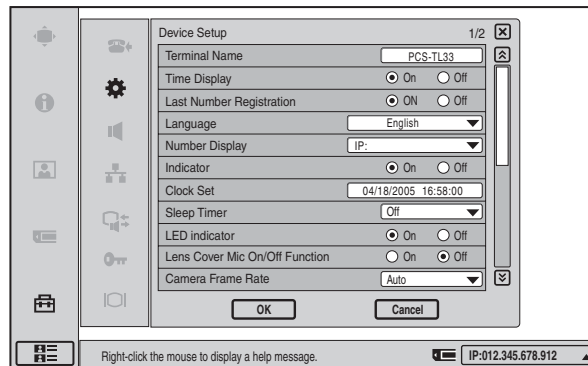

### Terminal Name

Input the terminal name to report when the system is connected to an external multipoint videoconferencing system.

### Time Display

Select whether to show the elapsed time on the display during the videoconference.

**On:** Elapsed time is displayed.

**Off:** Elapsed time is not displayed.

### Last Number Registration

Select whether or not to register the remote party in the Phone Book after the videoconference has finished.

**On:** If the remote party has not yet been registered in the Phone Book, the message “Register this participant in the list?” appears on the display after the videoconference has finished. When you click “OK”, the List Edit menu opens.

**Off:** The above message does not appear.

### Language

Select the language to show on the screen.

**English:** The display language is set to English.

**Finnish:** The display language is set to Finnish.

**French:** The display language is set to French.

**German:** The display language is set to German.

**Italian:** The display language is set to Italian.

**Japanese:** The display language is set to Japanese.

**Korean:** The display language is set to Korean.

**Portuguese:** The display language is set to Portuguese.

**Russian:** The display language is set to Russian.

**Simplified Chinese:** The display language is set to Simplified Chinese.

**Spanish:** The display language is set to Spanish.

**Swedish:** The display language is set to Swedish.

**Thai:** The display language is set to Thai.

**Traditional Chinese:** The display language is set to Traditional Chinese.

### Number Display

Select the information to display as identification for your system in the launcher menu, such as IP or SIP information.

**IP:** Displays your IP address.

**SIP: User Name:** Displays the SIP user name registered with the SIP server when conducting a videoconference using SIP.

**SIP: Address:** Displays the SIP address when conducting a videoconference using SIP.

**GK: User Alias:** Displays the registered gatekeeper user alias when using gatekeeper.

**GK: User Number:** Displays the registered gatekeeper user number when using gatekeeper.

**NAT: Address:** Displays the NAT address when connected to a network using NAT.

**No display:** Does not display any IP or SIP information.

#### Note

If the optional SIP software, PCSA-SP1, is not installed, “SIP: User Name” and “SIP: Address” will not appear.

### Indicator

Select whether the packet loss, mic gain, sending/receiving still image, sending/receiving DSM data, encrypted conference in progress (Standard/Proprietary), transmission mode, voice only\*, and network congestion indicators are shown.

**On:** Indicators are shown.

**Off:** Indicators are not shown.

\* Only enabled when Line I/F is set to SIP.

### Clock Set

Enter the current date and time.

#### Note

If the AC adapter is left unplugged for more than 24 hours, the date and time setting will be cleared.

### Sleep Timer

Select the time interval until the standby condition is automatically activated.

The standby condition is released when the | / ⏻ (Power) switch is pressed or a call is received.

**5 min.:** The standby condition is activated when there has been no activity for 5 minutes.

**15 min.:** The standby condition is activated when there has been no activity for 15 minutes.

**60 min.:** The standby condition is activated when there has been no activity for 60 minutes.

**Off:** The standby condition is not activated automatically.

### LED Indicator

Select whether the LED indicators of the system are operative or not.

**On:** LED indicators will light.

**Off:** LED indicators will not light.

#### Note

Even if the “Off” setting is chosen, the | / ⏻ (Power) indicator remains lit.

### Lens Cover Mic On/Off Function

Select whether the mic turns on or off based on whether the lens cover is open or closed.

**On:** When the lens cover is closed, the mic turns off.

**Off:** Opening and closing of the lens cover does not affect the mic.

### Camera Frame Rate

Select the camera frame rate.

**Auto:** Automatically adjusts according to the illumination of the ambient environment.

**15fps:** Transmit at a rate of 15 frames per second.

**30fps:** Transmit at a rate of 30 frames per second.

## Page 2/2

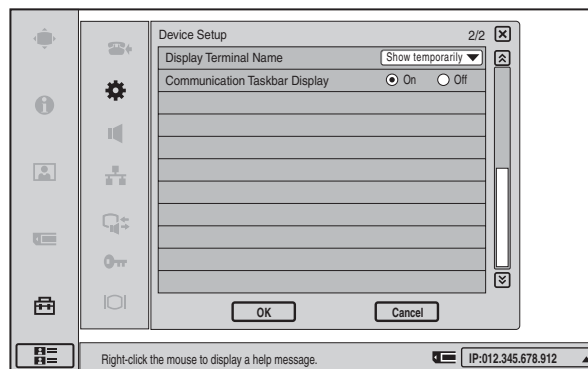

### Display Terminal Name

Allows you to select whether to display the connected terminal names on the monitor screen.

**Off:** Not to display the terminal names.

**Show temporarily:** Display the terminal names for a brief moment.

**Always show:** Display the terminal names.

### Communication Taskbar Display

Select whether to display the taskbar during communication.

**On:** Displays the taskbar during communication.

**Off:** Does not display the taskbar during communication.

## Audio Setup Menu

The Audio Setup menu is used to set various audio items.

### Page 1/1

The level meter indicating the audio input level is displayed.

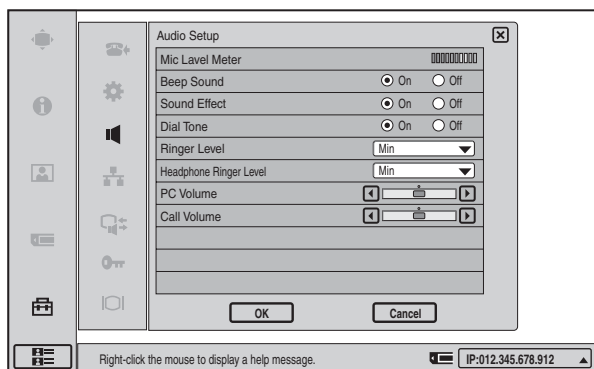

### Beep Sound

Selects whether the beep sounds when you perform a mouse operation.

**On:** Enables beep.

**Off:** Disables beep.

### Sound Effect

Selects whether or not to output the sound when the system starts up, a videoconference starts, a videoconference ends, or a videoconference using SIP is put on hold.

**On:** Outputs the sound.

**Off:** Does not output the sound.

### Dial Tone

Selects whether or not to output a dial tone when you are dialing.

**On:** Outputs the dial tone.

**Off:** Does not output the dial tone.

### Ringer Level

Selects the ringer volume when you receive a call.

To disable the ringer tone, select the “Off” setting.

To use the ringer tone, select one of the following settings: “Min”, “Mid”, “Loud”.

### Headphone Ringer Level

Use this item to select the headphone ringer volume for incoming calls.

To disable the ringer tone, select the “Off” setting.

To use the ringer tone, select one of the following settings: “Min”, “Mid”, “Loud”.

### PC Volume

Use this item to set the speaker/headphone volume for the computer display.

### Call Volume

Use this item to set the speaker/headphone volume for videoconferences.

## Network Setup Menu

Lets you make LAN and SIP related settings.

*For details on the settings, consult with the network administrator.*

*For details on setting up each network using LAN, see “Setting Up the Network Configurations” on page 43.*

*For details on videoconferencing using SIP, see chapter 7.*

### Note

The SIP Setup menu can be accessed only if the optional SIP software PCSA-SP1 is installed.

### LAN Page 1/3

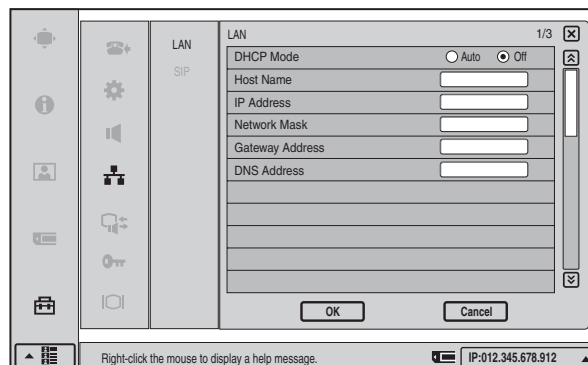

### DHCP Mode

Selects whether DHCP (Dynamic Host Configuration Protocol) server is enabled or not.

**Auto:** The IP address and subnet mask are automatically assigned.

In this case, confirm the assigned IP address, subnet mask, gateway address, and DNS address in the launcher menu or the Machine Information menu after the LAN connection is completed.

**Off:** Sets “DHCP Mode” to “Off”. In this case, enter the IP address, subnet mask, gateway address, and DNS address.

### Host Name

Enter the host name.

### IP Address

Enter the IP address.

**Network Mask**

Enter the subnet mask.

**Gateway Address**

Enter the default gateway address.

**DNS Address**

Enter the DNS (Domain Name System) address.

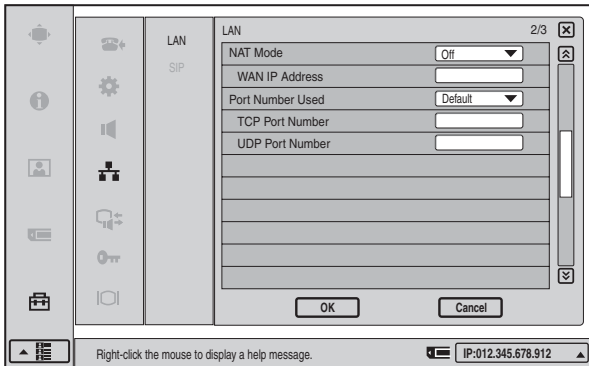
**LAN Page 2/3****NAT Mode**

Selects whether you connect the system to a local network using NAT (Network Address Translation) that enables sharing of one global IP address for multiple computers on the same LAN.

**Auto (UPnP):** Enables the UPnP function.

**On:** Enables NAT mode.

**Off:** Disables NAT mode.

**WAN IP Address**

Enter the IP address of a global network to be used for NAT mode.

**Port Number Used**

Selects whether or not to fix the TCP port number and UDP port number.

**Custom:** Uses the port numbers set by the user.

**Default:** Uses the default port numbers.

TCP port number: 2253 - 2255

UDP port number: 49152 - 49239

**Note**

When “Port Number Used” is set to “Default” after it has been set to “Custom”, restart the system to reset the setting.

**TCP Port Number**

When “Port Number Used” is set to “Custom”, enter the TCP port number.

The display shows usable port numbers.

**UDP Port Number**

When “Port Number Used” is set to “Custom”, enter the UDP port number.

The display shows usable port numbers.

For details on the port numbers used, see “List of Port Numbers Used on the PCS-TL33” on page 119.

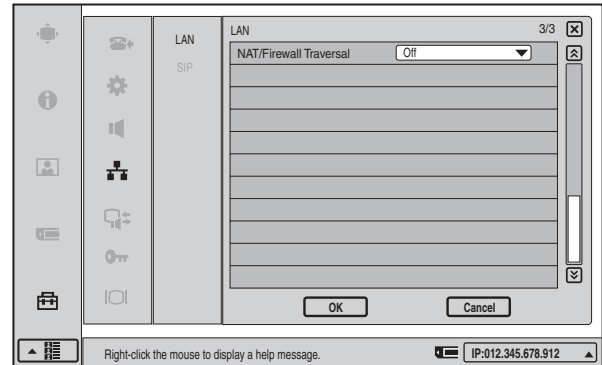
**LAN Page 3/3****NAT/Firewall Traversal**

Allows you to select whether to use H.460 to traverse firewalls and conduct conferences with terminals on other networks.

**On (H.460):** Enables conferences that traverse H.460 standard firewalls.

**Off:** Disables conferences that traverse firewalls.

**Note**

You must set up the gatekeeper to use this function.

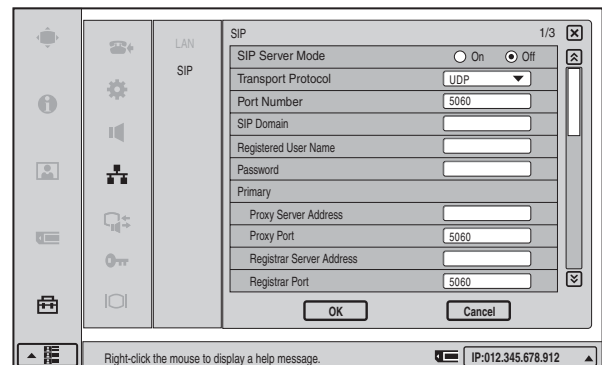
**SIP Page 1/3****SIP Server Mode**

Select whether to use SIP server.

**On:** Use SIP server.

**Off:** Do not use SIP server.

**Transport Protocol**

Select the protocol to be used for SIP.

**TCP:** Use TCP (Transmission Control Protocol).

**UDP:** Use UDP (User Datagram Protocol).

### Port Number

Input the port for the SIP server.

### SIP Domain

Enter the SIP domain name.

Up to 17 alphanumeric characters can be entered.

### Registered User Name

Enter the user name registered on the SIP server.

Up to 17 alphanumeric characters can be entered.

### Password

Enter the password registered on the SIP server.

Up to 17 alphanumeric characters can be entered.

### Primary

Enter parameters for the first server.

### Proxy Server Address

Enter the address of a proxy server to be used.

### Proxy Port

Input the port for the SIP proxy server.

### Registrar Server Address

Enter the address of a registrar server to be used.

### Registrar Port

Input the port for the SIP registrar server.

## SIP Page 2/3

The screenshot shows the SIP configuration interface on page 2/3. It features a sidebar with navigation icons and a main content area with three server configuration sections: Secondary, Trinity, and a fourth server. Each section contains four input fields: Proxy Server Address, Proxy Port (pre-filled with 5060), Registrar Server Address, and Registrar Port (pre-filled with 5060). The interface includes 'OK' and 'Cancel' buttons at the bottom.

### Secondary

Enter parameters for the second server.

### Trinity

Enter parameters for the third server.

## SIP Page 3/3

The screenshot shows the SIP configuration interface on page 3/3. It displays the configuration for the fourth server. The fields include Proxy Server Address, Proxy Port (5060), Registrar Server Address, and Registrar Port (5060). The interface includes 'OK' and 'Cancel' buttons at the bottom.

### Fourth

Enter parameters for the fourth server.

## Communication Mode Menu

Lets you make communication related settings.

## Page 1/3

The screenshot shows the Communication Mode Menu on page 1/3. It lists various communication settings: Video Mode (Auto), Video Frame (15fps), Audio Mode (Auto), LAN Bandwidth (1024kbps), Input LAN Bandwidth, Far End Camera Control (radio buttons for On/Off), H.239(Presentation) (radio buttons for On/Off), Line I/F (IP), Lip Sync (radio buttons for On/Off), and More Options Enable (radio buttons for On/Off). The interface includes 'OK' and 'Cancel' buttons at the bottom.

### Dial

#### Video Mode

Select the compression method to be used for transmitting video information.

**Auto:** Match the method selected at the far-end system.

**H.264:** Use H.264 compliant compression.

**MPEG4:** Use MPEG4 compliant compression.

**H.263+:** Use H.263+ compliant compression.

**H.261:** Use H.261 compliant compression (for still image transmission [see Annex D]).

**SIP: No-Video:** Use voice only.

#### Note

“SIP: No-Video” is only enabled when the optional PCSA-SP1 SIP software is installed.

## Video Frame

Select the send video frame rate.

**Auto:** The frame rate adjusts automatically.

**15fps:** Send CIF format video at a maximum rate of 15 frames per second.

**30fps:** Send CIF format video at a maximum rate of 30 frames per second.

### Note

If the video frame rate is set to 30fps when the camera frame rate is set to 15fps or Auto, the actual frame rate of the picture may be 15fps, depending on the usage environment.

## Audio Mode

Select an audio compression method.

**Auto:** Match the audio mode selected at the far-end system.

**MPEG4 Audio:** Use MPEG4 compliant compression.

**G.722:** Use G.722 compliant compression.

**G.729:** Use G.729 compliant compression.

**G.728:** Use G.728 compliant compression.

**G.711:** Use G.711 compliant compression.

### Note

If the far-end videoconferencing system does not support the audio compression method selected at the PCS-TL33, the G.711 method will automatically be used.

## LAN Bandwidth

Select the bandwidth to be used for transmission.

Available settings are 64 kbps, 128 kbps, 256 kbps, 384 kbps, 512 kbps, 768 kbps, 1024 kbps, 1536 kbps, 2048 kbps, and “User Input”.

## Input LAN Bandwidth

When “User Input” was selected for “LAN Bandwidth”, enter the bandwidth value here.

## Far End Camera Control

Select whether to enable far-end camera control.

**On:** Normally this setting should be selected, to allow control of the far-end camera.

**Off:** Disable control of the far-end camera.

## H.239 (Presentation)

Select whether to use the H.239 compliant presentation function.

**On:** Enables use of the H.239 compliant presentation function.

**Off:** Disables use of the H.239 compliant presentation function.

## Line I/F

Selects the line interface to be used normally.

**IP:** Connect to a videoconferencing system on the remote site via a LAN.

**SIP:** Connects to an IP phone or similar using SIP.

### Note

You can also select a line interface for individual calls using the line interface selection in the launcher menu.

## Lip Sync

Select whether to enable the Lip Sync function for synchronizing the lip movement and audio of the transmission source.

**On:** Enable the Lip Sync function.

**Off:** Disable the Lip Sync function.

## More Options Enable

When “More Options Enable” is set to “On”, dial settings for entries in the Phone Book and Private Phone Book can be configured individually.

**On:** “More Options” appears in the List Edit menu of the Phone Book and Private Phone Book, and you can click on it to configure Video Mode, Video Frame, Audio Mode, Far End Camera Control, and H.239 (Presentation) settings. You can configure these dial settings for each individual entry.

The Dial settings configured in the Communication Mode menu are applied to entries that have not been configured with More Options.

**Off:** The Dial settings configured in the Communication Mode menu are applied to all entries in the Phone Book and Private Phone Book.

## Page 2/3

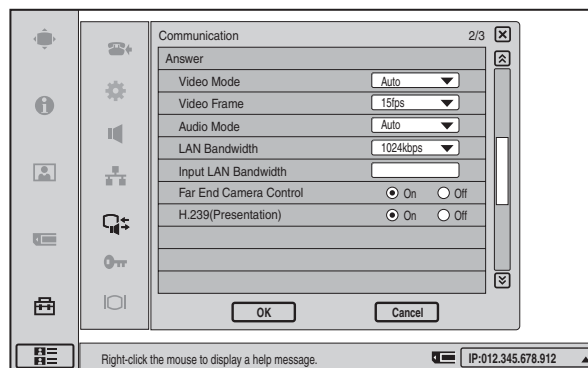

## Answer

### Video Mode

Select the compression method to be used for receiving video information.

**Auto:** Match the method selected at the far-end system.

**H.264:** Use H.264 compliant compression.

**MPEG4:** Use MPEG4 compliant compression.

**H.263+:** Use H.263+ compliant compression.

**H.261:** Use H.261 compliant compression.

**SIP: No-Video:** Use voice only.



**Note**

“SIP: No-Video” is only enabled when the optional PCSA-SP1 SIP software is installed.

**Video Frame**

Select the receive video frame rate.

**Auto:** The frame rate adjusts automatically.

**15fps:** Receive CIF format video at a maximum rate of 15 frames per second.

**30fps:** Receive CIF format video at a maximum rate of 30 frames per second.

**Audio Mode**

Select an audio compression method for reception.

**Auto:** Match the audio mode selected at the far-end system.

**MPEG4 Audio:** Use MPEG4 compliant compression.

**G.722:** Use G.722 compliant compression.

**G.729:** Use G.729 compliant compression.

**G.728:** Use G.728 compliant compression.

**G.711:** Use G.711 compliant compression.

**Note**

If the far-end videoconferencing system does not support the audio compression method selected at the PCS-TL33, the G.711 method will automatically be used.

**LAN Bandwidth**

Select the bandwidth to be used for reception.

Available settings are 64 kbps, 128 kbps, 256 kbps, 384 kbps, 512 kbps, 768 kbps, 1024 kbps, 1536 kbps, 2048 kbps, and “User Input”.

**Input LAN Bandwidth**

When “User Input” was selected for “LAN Bandwidth”, enter the bandwidth value here.

**Far End Camera Control**

Select whether to enable far-end camera control.

**On:** Normally this setting should be selected, to allow control of the far-end camera.

**Off:** Disable control of the far-end camera.

**H.239 (Presentation)**

Select whether to use the H.239 compliant presentation function.

**On:** Enables use of the H.239 compliant presentation function.

**Off:** Disables use of the H.239 compliant presentation function.

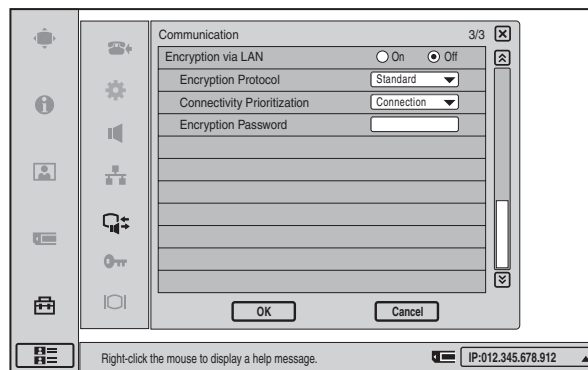
**Encryption via LAN**

Select whether to use the encryption feature.

**On:** Use the LAN encryption feature. When “On” is selected, you must set the encryption protocol, connection method, and encryption password.

**Off:** Do not use the LAN encryption feature.

**Encryption Protocol**

Select the type of encryption protocol.

**Standard:** Use standard encryption.

**Proprietary:** Use Sony proprietary encryption.

**Connectivity Prioritization**

Select the connectivity method.

**Connection:** The connection is given priority. For terminals without LAN encryption capability or terminals where “Encryption via LAN” is set to “Off”, conduct a videoconference without encryption.

**Encryption:** The encryption is given priority. For terminals without LAN encryption capability or terminals where “Encryption via LAN” is set to “Off”, a videoconference cannot be conducted.

**Encryption Password**

When “Proprietary” has been selected, a password must be set to enable holding a videoconference using LAN encryption.

The password must be 13 - 20 characters long.

**Note**

When “Proprietary” has been selected, it will not be possible to connect to the following types of terminals: terminals without LAN encryption capability, terminals where “Encryption via LAN” is set to “Off”, terminals where a different password is set.

## Administrator Setup Menu

The Administrator Setup menu is used for the system administrators. When you specify an administrator password in this menu, that password will be required when making changes in the setup menus (excluding the Display Setup menu) and Phone Book. Entering the password is also required to access the Administrator Setup menu.

### Page 1/11

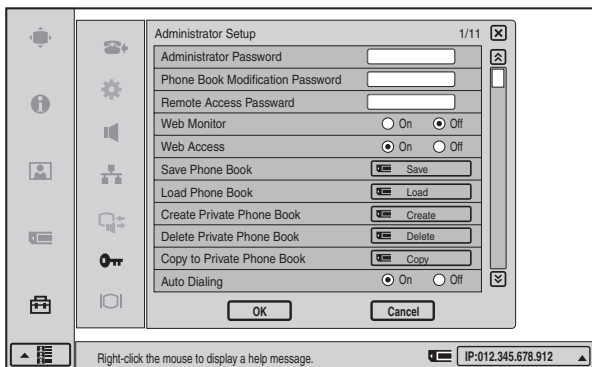

### Administrator Password

Sets a password up to ten characters long for the system administrator.

This password will be required when saving configurations in the setup menus (excluding the Display Setup menu) and accessing the Administrator Setup menu and Phone Book.

### Phone Book Modification Password

Sets a password up to ten characters long for modifying the Phone Book.

### Remote Access Password

Sets a password up to ten characters long for accessing this System from a Web browser or telnet. Accessing from a Web browser is also enabled by entering the administrator password.

### Web Monitor

Selects whether to permit the monitoring of a videoconference (automatic updating of JPEG images) from a Web browser.

**On:** Permits the monitoring of a videoconference via a Web browser.

**Off:** Prohibits the monitoring of a videoconference via a Web browser.

### Web Access

Selects whether or not to permit accessing the PCS-TL33 via a Web browser or Telnet.

**On:** Permits accessing via a Web browser or Telnet.

**Off:** Prohibits accessing via a Web browser or Telnet.

### Save Phone Book

Saves the data in the Phone Book in a “Memory Stick”. The data in the “Memory Stick” will be overwritten.

### Load Phone Book

Loads the data in the Phone Book from a “Memory Stick”. The data in the Phone Book will be overwritten.

### Create Private Phone Book

Selects to create an empty folder and file for a Private Phone Book in an inserted “Memory Stick”.

### Delete Private Phone Book

Selects to delete the Private Phone Book folder in the inserted “Memory Stick”.

### Copy to Private Phone book

Selects to copy all the contents of the Phone Book to a Private Phone Book in the inserted “Memory Stick”.

### Auto Dialing

You can create a Private Phone Book in a “Memory Stick”. This item is used to select whether or not to automatically dial the address of a single contact on a specified list in the Private Phone Book simply by inserting the “Memory Stick”.

**On:** Enables automatic dialing.

**Off:** Disables automatic dialing.

### Page 2/11

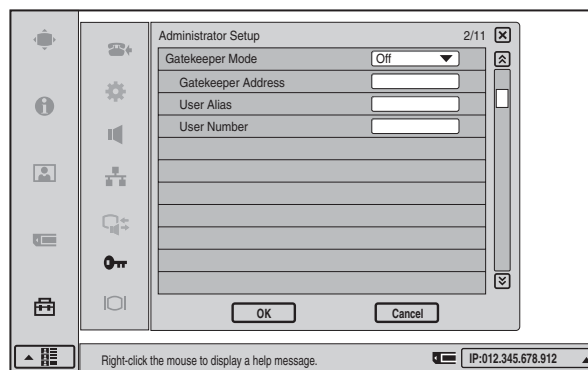

### Gatekeeper Mode

Sets whether you use the gatekeeper that controls access to a remote party.

Using the gatekeeper allows you to dial using the user name or user number.

**Auto:** Detects the gatekeeper automatically and uses it.

**On:** Enables use of the gatekeeper.

**Off:** Disables use of the gatekeeper.

### Gatekeeper Address

Enter the gatekeeper address used when “Gatekeeper Mode” is set to “On”.



## User Alias

Enter the user name (H.323 alias) to be registered in the gatekeeper.

## User Number

Enter the user number (E.164 number) to be registered in the gatekeeper.

## Page 3/11

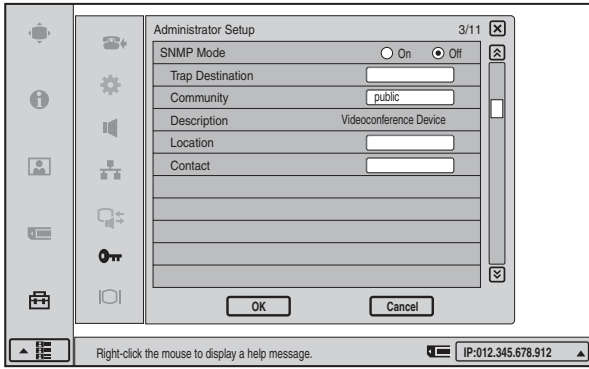

## SNMP Mode

Selects whether the SNMP (Simple Network Management Protocol) agent service is enabled or not.

**On:** Enables the SNMP agent service.

**Off:** Disables the SNMP agent service.

### Note

Changes made in the SNMP Mode setting take effect after restarting.

## Trap Destination

Enter the address of the trap destination SNMP manager.

## Community

Enter the community name managed by the SNMP manager. The default setting is “public”. Normally, there is no need to change.

## Description

Enter the description of this system. The default setting is “Videoconference Device” and cannot be changed.

## Location

Enter the location where this system is installed.

## Contact

Enter information on the administrator of this system.

## Page 4/11

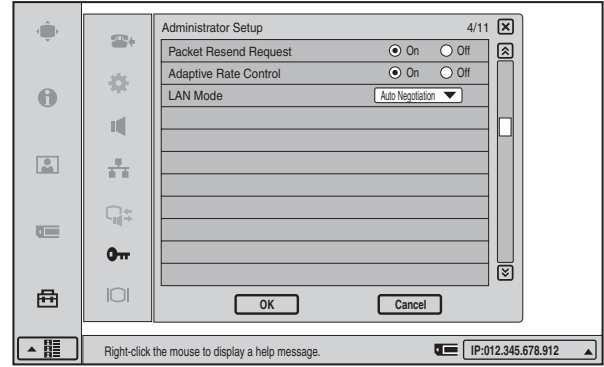

## Packet Resend Request

Selects whether or not to request to resend the packet when a packet loss occurs during communication.

**On:** Requests resending a packet.

**Off:** Does not request resending a packet.

## Adaptive Rate Control

Sets whether or not to always optimize the LAN bandwidth.

**On:** Always optimizes.

**Off:** Disables optimization of the LAN bandwidth.

### Note

This setting is enabled only when “Packet Resend Request” is set to “Off”. When “Packet Resend Request” is set to “On”, this item is always set to “On”.

## LAN Mode

Selects the interface type and the communication mode of the LAN connection.

**Auto Negotiation:** The interface type and the communication mode are recognized automatically.

**100Mbps Full Duplex:** Connects via 100BASE-TX in full duplex mode.

**100Mbps Half Duplex:** Connects via 100BASE-TX in half duplex mode.

**10Mbps Full Duplex:** Connects via 10BASE-T in full duplex mode.

**10Mbps Half Duplex:** Connects via 10BASE-T in half duplex mode.

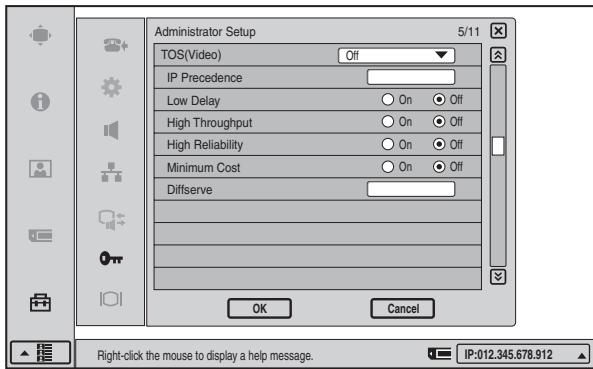

Each page allows you to configure TOS (Type of Service) Field settings by data type.

**Page 5/11: TOS (Video)**

Configure TOS (Type of Service) Field settings for video data.

**Page 6/11: TOS (Audio)**

Configure TOS (Type of Service) Field settings for audio data.

**Page 7/11: TOS (Presentation)**

Configure TOS (Type of Service) Field settings for the RGB data output from the Data Solution Module.

**Page 8/11: TOS (Camera Control)**

Configure TOS (Type of Service) Field settings for camera control signals.

**TOS**

Selects how to define the TOS (Type of Service) field for an IP datagram.

**IP Precedence:** Defines the TOS field as IP Precedence.

**Diffserve:** Defines the TOS field as Diffserve.

**Off:** Does not define the TOS field.

**IP Precedence**

Enter the IP Precedence value (0 – 7).

**Low Delay**

Selects whether or not to specify the bit rate of Low Delay for the TOS field.

**On:** Specifies the bit rate of Low Delay for the TOS field.

**Off:** Does not specify the bit rate of Low Delay for the TOS field.

**High Throughput**

Selects whether or not to specify the bit rate of High Throughput for the TOS field.

**On:** Specifies the bit rate of High Throughput for the TOS field.

**Off:** Does not specify the bit rate of High Throughput for the TOS field.

**High Reliability**

Selects whether or not to specify the bit rate of High Reliability for the TOS field.

**On:** Specifies the bit rate of High Reliability for the TOS field.

**Off:** Does not specify the bit rate of High Reliability for the TOS field.

**Minimum Cost**

Selects whether or not to specify the bit rate of Minimum Cost for the TOS field.

**On:** Specifies the bit rate of Minimum Cost for the TOS field.

**Off:** Does not specify the bit rate of Minimum Cost for the TOS field.

**Diffserve**

Enter the Diffserve value (0 – 63).

**Page 9/11**

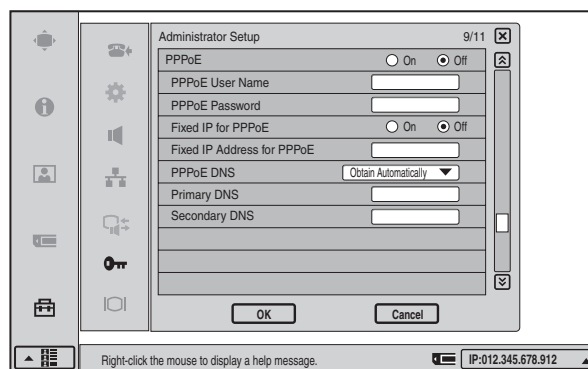

**PPPoE**

Selects whether or not to use PPPoE for LAN connection. You can use the B FLET'S or FLET'S ADSL services without connecting a router when using PPPoE.

**On:** Uses PPPoE for LAN connection.

**Off:** Does not use PPPoE.

**Notes**

- Operations of PPPoE for LAN connection are presently verified only for Japanese NTT B FLET'S and FLET'S ADSL services.
- "FLET'S" is a trademark of NTT East and NTT West Corporations in Japan.

**PPPoE User Name**

Enter a user name when you use PPPoE for LAN connection.

**PPPoE Password**

Enter a password when you use PPPoE for LAN connection.

**Fixed IP for PPPoE**

Selects whether or not to make a PPPoE connection using the static IP.

**On:** Uses the static IP for a PPPoE connection.

**Off:** Does not use the static IP for a PPPoE connection.

### Fixed IP Address for PPPoE

Enter the static IP address when “Fixed IP for PPPoE” is set to “On”.

### PPPoE DNS

Selects whether to obtain the DNS server addresses automatically or to specify them manually when connecting to LAN using PPPoE.

**Obtain Automatically:** Allows you to obtain the DNS server addresses automatically.

**Specify:** Specifies the DNS server addresses.

### Primary DNS

Enter a primary DNS address.

### Secondary DNS

Enter a secondary DNS address.

## Page 10/11

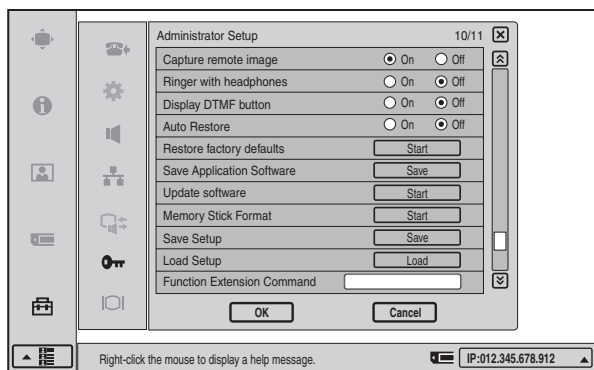

### Capture remote image

Select whether to automatically capture thumbnail still images of the remote party when a videoconference has started.

**On:** Automatically capture thumbnail images.

**Off:** Do not automatically capture thumbnail images.

### Ringer with headphones

Select whether the ringer on the main unit also rings when headphones are in use.

**On:** Enable ringer sound from speaker on main unit also.

The volume of the ringer tone depends on the headphone ringer level setting.

**Off:** Disable ringer sound from speaker on main unit.

### Display DTMF button

Select whether to display the DTMF button in the communication screen. Clicking the DTMF button displays the DTMF soft keyboard.

**On:** Display the DTMF button.

**Off:** Do not display the DTMF button.

### Restore factory defaults

Restores the system to the factory default settings.

All settings revert to defaults and Phone Book data is deleted.

### Save Application Software

Saves application software to a “Memory Stick”.

### Update software

Performs a software update or rollback using a “Memory Stick.”

### Note

When performing a rollback, you can revert as far back as the factory-installed version.

### Memory Stick Format

Formats a “Memory Stick”.

### Save Setup

Saves the settings information to a “Memory Stick”.

### Load Setup

Loads settings information from a “Memory Stick”.

### Function Extension Command

Enter the command to begin use of IPELA VC Link service.

### Note

IPELA VC Link service is only available in Japan.

For more about the IPELA VC Link service, consult your Sony dealer.

### Auto Restore

Select whether to turn the system on automatically after recovering from a power outage.

**On:** Automatically turns the system on when power is restored.

**Off:** Does not automatically turn the system on when power is restored.

## Page 11/11

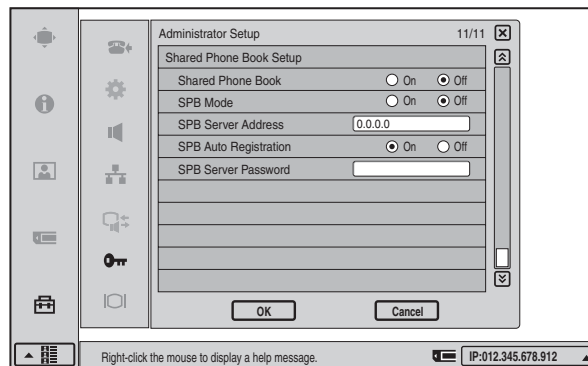

### Shared Phone Book

Allows you to select whether to use the Shared Phone Book located on the server.

**On:** Enables use of the Shared Phone Book.

**Off:** Disables use of the Shared Phone Book.

### SPB Mode

Selects whether to use the server managing the Shared Phone Book.

**On:** Enables use of the server managing the Shared Phone Book.

**Off:** Disables use of the server managing the Shared Phone Book.

### SPB Server Address

Enter the IP address for the server managing the Shared Phone Book.

### SPB Auto Registration

Selects whether information about terminals is registered automatically on the server managing the Shared Phone Book.

**On:** Enables automatic registration on the server managing the Shared Phone Book.

**Off:** Disables automatic registration on the server managing the Shared Phone Book.

### SPB Server Password

Enter the password for the server managing the Shared Phone Book.

## Display Setup Menu

Lets you make display related settings. Settings are made separately for videoconference mode and PC (computer display) mode.

For details on how to make the settings, see “Adjusting the Picture Quality on the Display” on page 89.

### Videoconference Page 1/1

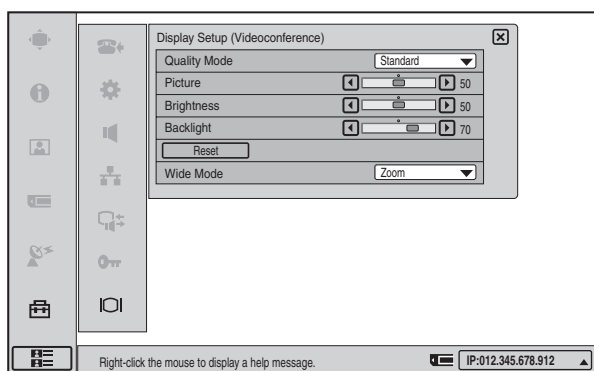

### Quality Mode

Selects the color tone of the image.

**Vivid:** Slightly bluish color tone.

**Standard:** Setting between Vivid and Pro.

**Pro:** Slightly reddish color tone.

### Picture

Adjusts the picture contrast.

The contrast increases as the value gets larger.

### Brightness

Adjusts the picture brightness.

The brightness increases as the value gets larger.

### Backlight

Adjusts the brightness of the backlight.

The backlight gets brighter as the value gets larger.

### Reset

Resets the settings to the default condition.

### Wide Mode

Switches the display mode.

**Normal:** Shows the 4:3 image as is.

**Wide:** Stretches the 4:3 image horizontally to fit the wide screen.

**Zoom:** Enlarges the 4:3 image and then crops the top and bottom to fit the wide screen.

### Note

When Picture-and-Picture or Side-by-Side is selected for the screen layout, the display does not change, even when Wide Mode is adjusted.

### PC Page 1/2

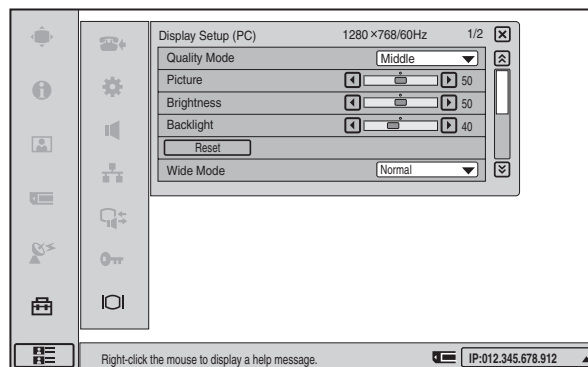

### Quality Mode

Selects the color temperature of the image.

**Low:** Sets the color temperature to Low.

**Middle:** Sets the color temperature to Middle.

**High:** Sets the color temperature to High.

### Picture

Adjusts the picture contrast.

The contrast increases as the value gets larger.

**Brightness**

Adjusts the picture brightness.  
The brightness increases as the value gets larger.

**Backlight**

Adjusts the brightness of the backlight.  
The backlight gets brighter as the value gets larger.

**Reset**

Resets the settings to the default condition.

**Wide Mode**

Switches the display mode.  
When a WXGA 1280 × 768 image is input, it is displayed in wide mode regardless of the display mode setting.

**Normal:** Shows the 4:3 image as is.

**Wide:** Stretches the 4:3 image horizontally to fit the wide screen.

**Zoom:** Enlarges the 4:3 image and then crops the top and bottom to fit the wide screen.

**Note**

When Picture-and-Picture or Side-by-Side is selected for the screen layout, the display does not change, even when Wide Mode is adjusted.

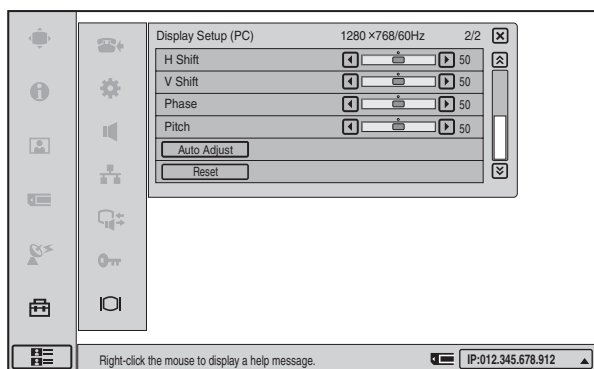
**PC Page 2/2****H Shift**

Use this item to shift the entire screen horizontally.  
Moves the screen left and right.

**V Shift**

Use this item to shift the entire screen vertically.  
Moves the screen up and down.

**Phase**

Use this item to minimize character blurring and lateral fringes.

**Pitch**

Use this item to remove large longitudinal fringes.

**Auto Adjust**

Automatically adjusts the phase and pitch.

**Reset**

Resets the settings to the default condition.

**Screen Resolution/Refresh Rate**

Displays the screen resolution and refresh rate.

**Note**

The adjustment range of the H Shift and V Shift may differ depending on the specifications of the RGB signal input.

# Registering a Remote Party in the Phone Book

You can register the IP address and other information for a remote party in the Phone Book, allowing you to dial the party very easily.

Up to 500 remote parties can be registered in the Phone Book. You can also store a still image such as a participant's portrait in the index list.

In addition to the regular Phone Book of the Video Communication System, you can create a Private Phone Book on a "Memory Stick".

## Registering a New Remote Party

- 1 In the launcher menu, click  (Phone Book).

The Phone Book menu opens.

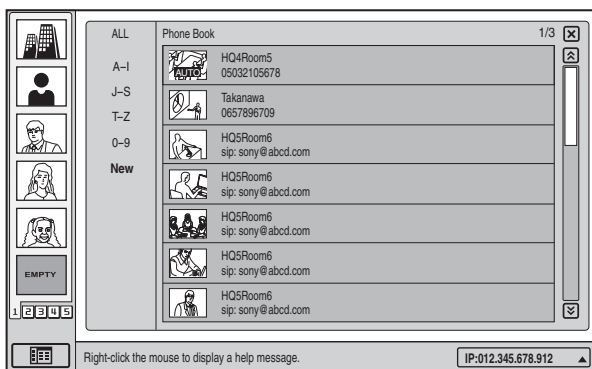

- 2 Click "New".

The List Edit menu appears.

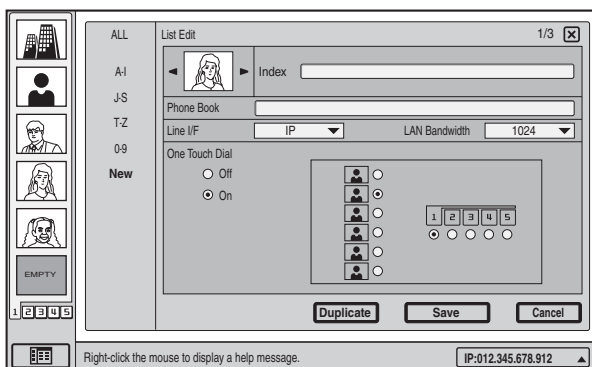

- 3 Enter the name of a remote party in the Index text box.

For information on character input, see "Entering Characters" on page 23.

- 4 Enter the IP address of the remote party in the IP address text box.
- 5 Select the line interface you are using to connect to a remote party with "Line I/F".

**IP:** Connect to a videoconferencing system on the remote site via a LAN.

**SIP:** Connect to an IP phone using SIP.

### Note

The "Line I/F" options differ depending on the software installed in the PCS-TL33.

For information on SIP, see chapter 7.

- 6 Set the LAN bandwidth to use.
- 7 Select the thumbnail image to be shown in the Phone Book. You can select the line interface icon or a still image automatically captured during a videoconference.



Click   to select the image.

When a "Memory Stick" is inserted into the unit, you can also select still images stored on the "Memory Stick."

For details on the automatic capturing of still images, see "Saving Remote Party Pictures Automatically – Automatic Image Capture Feature" on page 68.

- 8 Specify whether to include the entry in the One Touch Dial list. To do this, select the group and the position within the group.
- 9 Click "Save".

The settings are registered in the Phone Book.

### To configure different dial settings for each entry

When you set "More Options Enable" to "On" in the Dial settings of the Communication Mode menu, "More Options" appears in the List Edit menu. Clicking this allows you to configure Video Mode, Video Frame, Audio Mode, Far End Camera Control, and H.239 (Presentation) settings for each entry individually. Click "Back" to return to the standard List Edit menu.

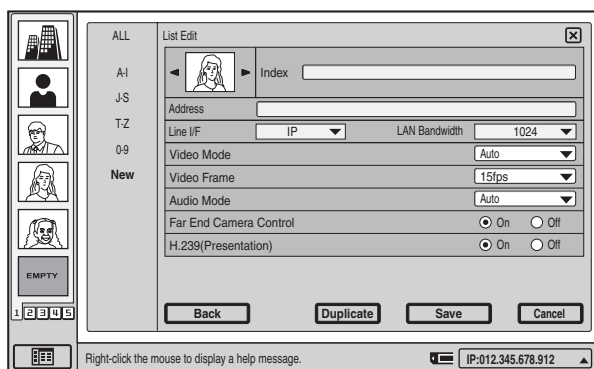

## Changing the Contents of the Phone Book

You can change the IP address, name, or other setting registered in the Phone Book.

- 1 Open the Phone Book menu.
- 2 Move the mouse cursor to the entry you want to change, and click “Edit”.

The List Edit menu appears.

- 3 Change the IP address, name, or other setting.
- 4 Click “Save”.

The corrected entry is saved.

### To configure different dial settings for each entry

When you set “More Options Enable” to “On” in the Dial settings of the Communication Mode menu, you can configure Video Mode, Video Frame, Audio Mode, Far End Camera Control, and H.239 (Presentation) settings for each entry individually using the List Edit menu.

For details, see “Registering a New Remote Party” on page 38.

## Deleting a Registered Remote Party

Follow the procedure below to delete a remote party from the Phone Book.

- 1 Open the Phone Book menu.
- 2 Move the mouse cursor to the entry you want to delete, and click .

The message “Delete Entry?” appears.

- 3 Click “OK”.

The selected party is deleted.

### To cancel deleting

Click “Cancel” in step 3.

#### Note

If the deleted party has been registered for One Touch Dial, the One Touch Dial entry will also be deleted.

## Copying an Entry in the Phone Book

- 1 Open the Phone Book menu.
  - 2 Move the mouse cursor to the entry you want to copy, and click “Edit”.
- The List Edit menu appears.
- 3 Click “Duplicate”.

The data for the selected entry are copied, and the file name is followed by “-1, -2, -3”. You can use the data for another entry after modifying only the necessary items.

#### Note

Even if the copied entry was registered in the One Touch Dial, this information is not copied.

## Creating a Private Phone Book

You can create your own Phone Book (Private Phone Book) in a “Memory Stick”. Once the Private Phone Book is registered, inserting the “Memory Stick” into the system changes the Phone Book menu to the Private Phone Book menu. You can also activate the Auto Dial feature, allowing you to start dialing automatically to one of the lists simply by inserting the “Memory Stick”.

### To register a new remote party in a Private Phone Book

- 1 Insert a “Memory Stick” in which you want to register a remote party into the Memory Stick slot of the system.

Insert the “Memory Stick” with the front facing you and in the direction of the arrow on the top.



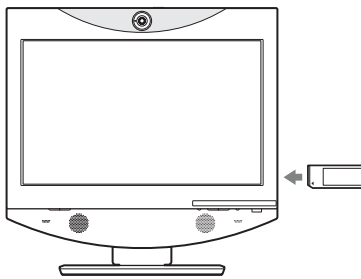

- 2 Open Page 1 of the Administrator Setup menu.

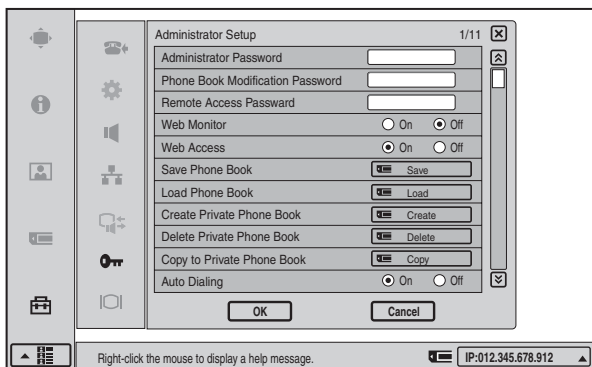

For details on how to open the menu, see “Opening the Setup Menu” on page 24.

- 3 Select “Create Private Phone Book”.

The message “Create a Private Phone Book?” appears.

- 4 Click “OK”.

An empty Private Phone Book is created in the “Memory Stick”.

- 5 Register a new remote party.

The procedure is the same as that for registering in the Phone Book. Proceed with steps 2 to 7 in “Registering a New Remote Party” on page 38.

The procedures for how to change the contents of the Private Phone Book, how to delete the registered remote party, or how to copy the setting of the Private Phone Book are the same as those for the Phone Book. Open the Private Phone Book menu and proceed with the steps described on page 39.

### To copy all the contents of the Phone Book to the Private Phone Book

Insert the “Memory Stick” in which you want to store the Private Phone Book into the Memory Stick slot on the system, then select “Copy to Private Phone Book” from Page 1 of the Administrator Setup menu. All the data

registered in the Phone Book are copied to the inserted “Memory Stick”.

### To delete the Private Phone Book from the “Memory Stick”

Insert the “Memory Stick” from which you want to delete the registered Private Phone Book into the Memory Stick slot on the system, then select “Delete Private Phone Book” from Page 1 of the Administrator Setup menu. All the data are deleted from the inserted “Memory Stick”.

### To dial a specified entry of the Private Phone Book automatically

If you set “Auto Dialing” in the Administrator Setup menu to “On”, you can automatically dial one of the entries in the Private Phone Book simply by inserting the “Memory Stick” on which the Private Phone Book is stored.

#### Note

Only one entry can be set for auto dial. The most recent address for which “Auto Dialing” was set to “On” will be used.

- 1 Open the Private Phone Book.
- 2 Move the mouse cursor to the remote party that you want to dial automatically, and click the “Edit”.

The List Edit menu appears.

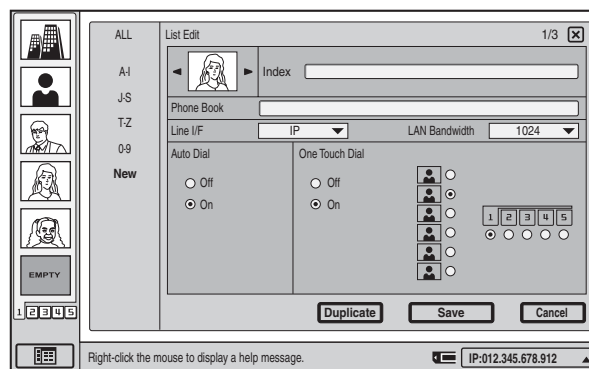

- 3 Set “Auto Dial” to “On” by clicking on the setting.
- 4 Click “Save”.

The setting is saved and “AUTO” appears on the Private Phone Book menu list.

### To exit from the Private Phone Book menu

Remove the “Memory Stick” in which the Private Phone Book is registered from the Communication Terminal. The screen returns to the Phone Book menu.



## Using the Shared Phone Book

Using the Shared Phone Book function, a phone book located on a server can be accessed by multiple Sony Video Communication System units.

For details about settings, consult your network administrator.

### Note

You cannot register, edit, delete, or attach images to parties in the Shared Phone Book. In addition, you cannot copy parties registered in the Shared Phone Book to the Private Phone Book.

## System configuration example

In this system configuration, sharing of a Phone Book using H.350 is enabled.

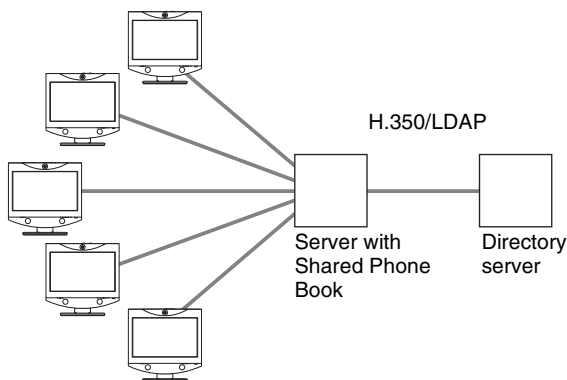

## To use the Shared Phone Book

Set “Shared Phone Book” and “SPB Mode” to “On” under Page 11/11 of the Administrator Setup menu, and enter the appropriate values for “SPB Server Address” and “SPB Server Password”.

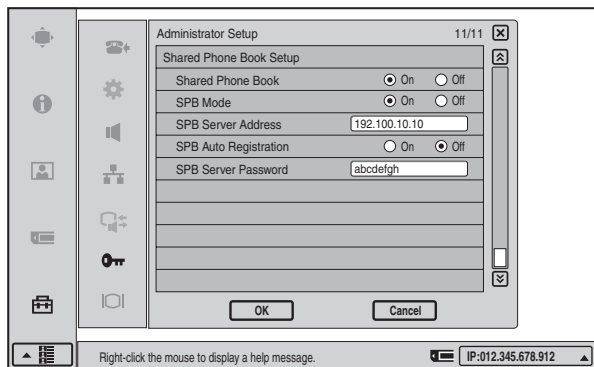

## To display the Shared Phone Book

Click  at the bottom left of the Phone Book screen to switch the display to the Shared Phone Book.

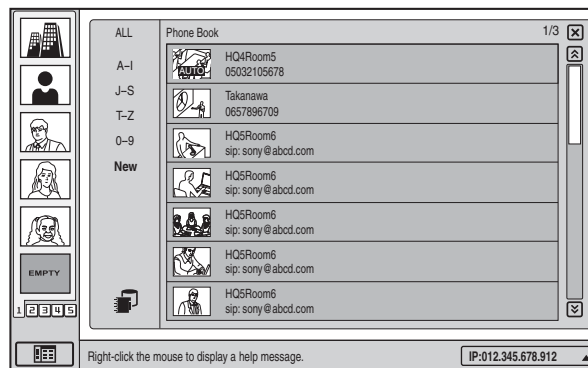

To switch back to the Phone Book or Private Phone Book from the Shared Phone Book, perform this operation again.

The procedure for dialing registered parties from the Shared Phone Book is the same as that for the Phone Book. For details on dialing, see “Calling a Remote Party Registered in the Phone Book” on page 53.

## Checking the History of Outgoing and Incoming Calls

Click  on the launcher menu to bring up the History menu.

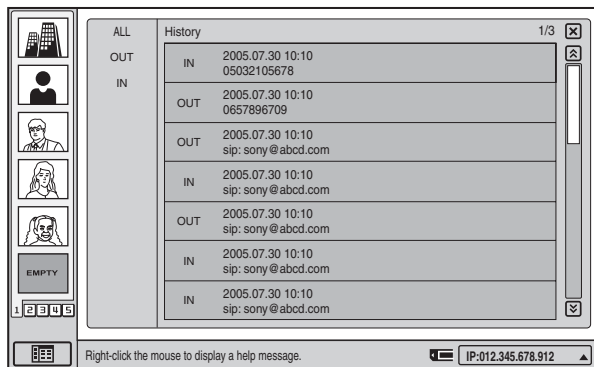

The History menu shows a list of remote parties to which the system was recently connected.

When “ALL” is selected, all outgoing and incoming calls are shown in chronological order. To display only outgoing or incoming calls, select “OUT” or “IN”.

When the list has several pages, a scroll bar will appear at the right side of the screen. To advance to the next page, click the Page button at the bottom of the scroll bar. To go back to the previous page, click the Page button at the top of the scroll bar.

You can also scroll through pages by moving the scroll bar with the mouse.

### To dial a history entry

Move the mouse cursor to the entry you want to dial, and click .

### To store a history entry in the Phone Book

Move the mouse cursor to the entry you want to add to the Phone Book, and click  (Save). For details, see “Changing the Contents of the Phone Book” on page 39.

### To delete a history entry

Move the mouse cursor to the entry you want to delete, and click .

#### Note

Starting with the newest entry, up to 40 outgoing or incoming calls are displayed in the history.

## Registering a Remote Party for One Touch Dial

You can register remote parties in the One Touch Dial list in the launcher menu, allowing you to dial them easily at any time.

Up to 30 remote parties from the Phone Book can be registered for One Touch Dial.

### One Touch Dial Registration

To register a party in the One Touch Dial, you use the List Edit menu of the Phone Book.

For information on the steps for One Touch Dial registration, see the section “Registering a New Remote Party” on page 38.

### To change a One Touch Dial registration from the Phone Book

If you change the contents of the Phone Book, the contents of the One Touch Dial registration also change accordingly.

For information on editing the Phone Book, see “Changing the Contents of the Phone Book” on page 39.

### To delete a One Touch Dial registration from the Phone Book

Using the List Edit menu of the Phone Book, you can delete a One Touch Dial registration.

For information on the steps for One Touch Dial deletion, see the section “Registering a New Remote Party” on page 38.

### To change a One Touch Dial registration from the launcher menu

- 1 On the launcher menu, move the mouse cursor to the entry that you want to edit, and then click  (Edit).

The List Edit menu opens.

- 2 Change the registration contents using the List Edit menu, and click “Save”.

The launcher menu appears again.

The launcher menu One Touch Dial contents and the Phone Book registration contents are changed at the same time.

## To delete a One Touch Dial registration from the launcher menu

On the launcher menu, move the mouse cursor to the entry that you want to delete, and then click .

The launcher menu appears again, and the deleted One Touch Dial entry is grayed out.

### Note

Deleting the One Touch Dial entry in this way will not delete the Phone Book entry.

## Registering the Private One Touch Dial

You can register the remote parties stored in the Private Phone Book in a “Memory Stick” for your own One Touch Dial list.

Once the Private One Touch Dial list is registered, inserting the “Memory Stick” into the system changes the One Touch Dial list in the launcher menu to the Private One Touch Dial list.

The procedures of the registration, deleting and editing of One Touch Dial are the same as those for the Phone Book of the system.

Up to 30 remote parties can be registered for your Private One Touch Dial list.

# Setting Up the Network Configurations

This section describes how to set up the network configurations for use with various networks.

*For details on the Network Setup menu, see “Network Setup Menu” on page 27.*

*For details on configurations, consult with the system administrator.*

## LAN (Connecting via DHCP)

### Configuration example

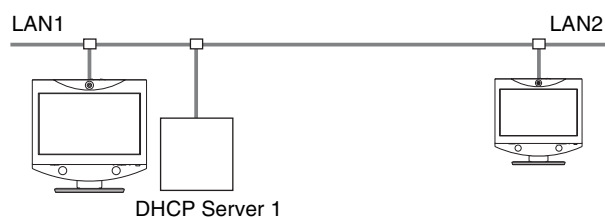

Set the “DHCP Mode” to “Auto” under Page 1/3 of the LAN Setup menu.

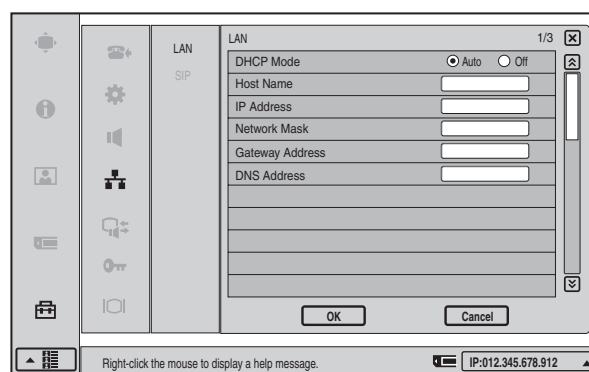

The setting has been configured properly if the IP address appears in the launcher menu.

### Note

The information that appears in the launcher menu may differ depending on the “Number Display” setting in the Device Setup menu. You can also click the Number Display portion and select the information to display from a list.

## To conduct a video conference

Select “IP” for the line interface, enter the remote party’s IP address in the text box, and dial.

You can set “IP” as the default line interface selection for the launcher menu by setting “Line I/F” to “IP” in the Dial settings of the Communication Mode menu.

For details on the setting, see “Communication Mode Menu” on page 29.

## LAN (Connecting Through a Router)

### Configuration example

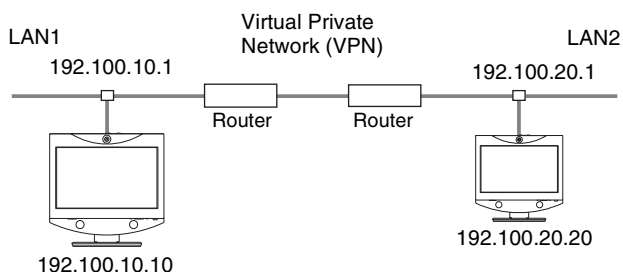

Enter a name in “Host Name” under Page 1/3 of the LAN Setup menu, set the “DHCP Mode” to “Off”, and enter the appropriate values for “IP Address”, “Network Mask”, and “Gateway Address”.

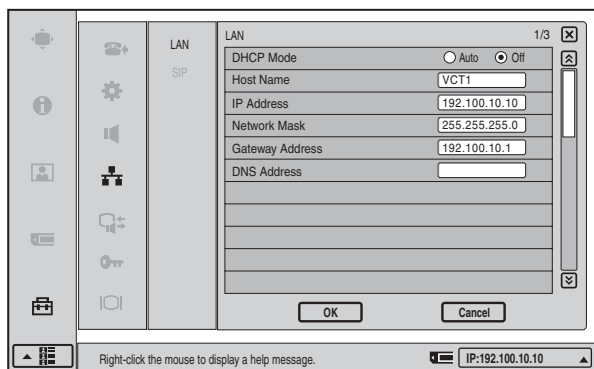

The setting has been configured properly if the correct IP address appears in the launcher menu.

### Note

The information that appears in the launcher menu may differ depending on the “Number Display” setting in the Device Setup menu. You can also click the Number Display portion and select the information to display from a list.

## To conduct a video conference

Select “IP” for the line interface, enter the remote party’s IP address in the text box, and dial.

You can set “IP” as the default line interface selection for the launcher menu by setting “Line I/F” to “IP” in the Dial settings of the Communication Mode menu.

For details on the setting, see “Communication Mode Menu” on page 29.

## LAN (Connecting Through a Gatekeeper)

### Configuration example

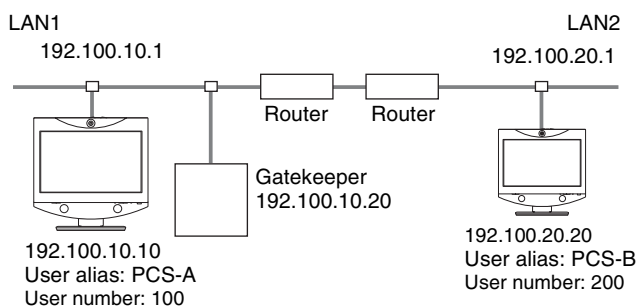

- 1 Enter a name in “Host Name” under Page 1/3 of the LAN Setup menu, set the “DHCP Mode” to “Off”, and enter the appropriate values for “IP Address”, “Network Mask”, and “Gateway Address”.

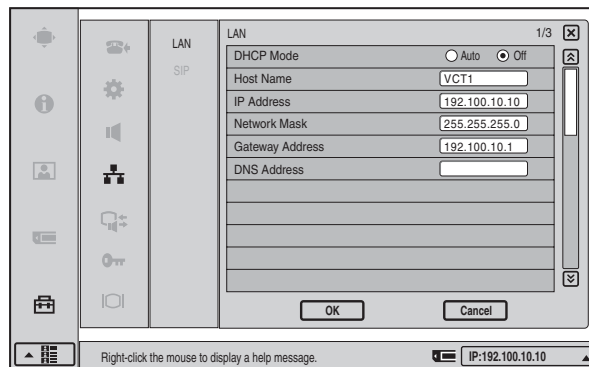

- 2 Set “Gatekeeper Mode” to “On” under Page 2/11 of the Administrator Setup menu, and enter the appropriate values for “Gatekeeper Address”, “User Alias”, and “User Number”.

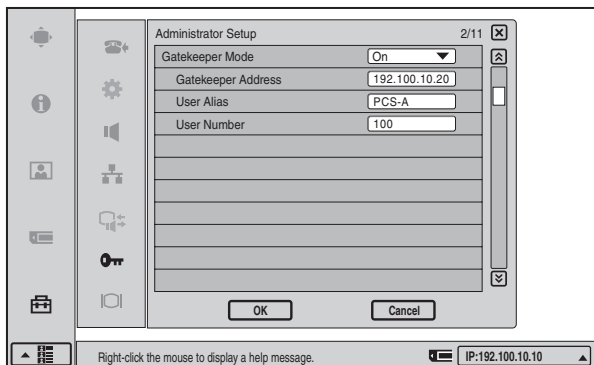

The setting has been configured properly if the correct IP address appears in the launcher menu and “Registration Confirmed” appears under “Gatekeeper” in Page 3/4 of the Status & Info menu.

### Note

The information that appears in the launcher menu may differ depending on the “Number Display” setting in the Device Setup menu. You can also click the Number Display portion and select the information to display from a list.

## To conduct a video conference

Select “IP” for the line interface, enter the user alias or user number set by the remote party in the number entry text box, and dial.

You can set “IP” as the default line interface selection for the launcher menu by setting “Line I/F” to “IP” in the Dial settings of the Communication Mode menu.

For details on the setting, see “Communication Mode Menu” on page 29.

## LAN (Connecting Through NAT)

Connection using NAT allows one IP address to be shared by several computers on the same LAN. This section describes how to set up videoconferences conducted in NAT and global IP environments.

### Configuration example

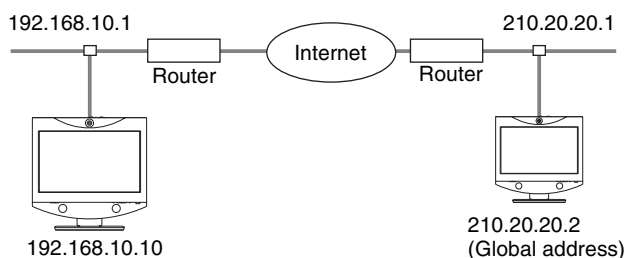

- 1 Enter a name in “Host Name” under Page 1/3 of the LAN Setup menu, set the “DHCP Mode” to “Off”, and enter the appropriate values for “IP Address”, “Network Mask”, and “Gateway Address”.

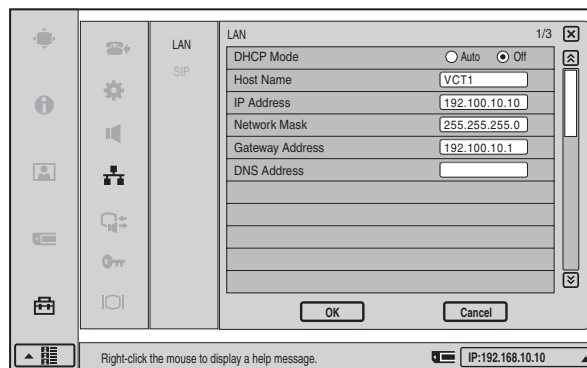

- 2 Set “NAT Mode” to “On” under Page 2/3 of the LAN Setup menu, and enter the appropriate IP address in “WAN IP Address”.

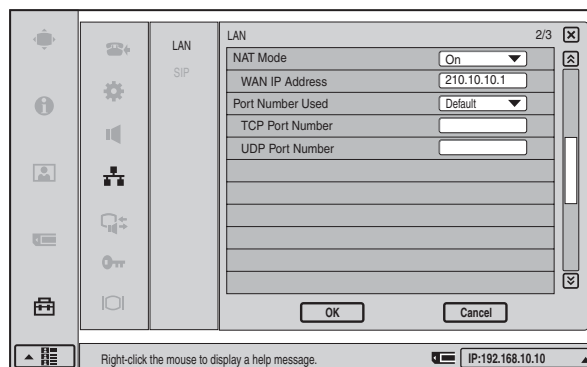

- 3 Remote parties must configure Page 1/3 of the LAN Setup menu in the same way.

### Note

If the remote parties are not in a NAT environment, NAT settings in the LAN Setup menu must be configured.

## To conduct a video conference

Select “IP” for the line interface, enter the remote party’s IP address in the text box, and dial.

You can set “IP” as the default line interface selection for the launcher menu by setting “Line I/F” to “IP” in the Dial settings of the Communication Mode menu.

For details on the setting, see “Communication Mode Menu” on page 29.

### Note

When using the terminal in the NAT environment, you can connect to a remote party (global IP), but for a remote

party to connect to you, you must configure your router settings. For details on router settings, consult with the system administrator.

## LAN (Connecting With H.460 Firewall Traversal)

You can use H.460 to traverse firewalls and conduct conferences with terminals on other networks.

### Configuration example

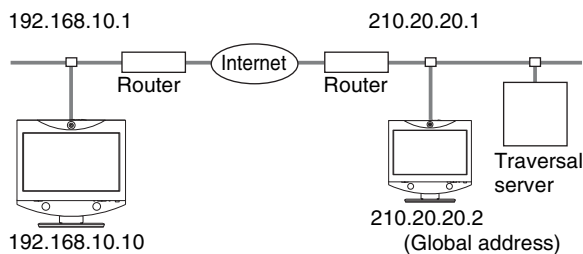

- 1 Set “NAT/Firewall Traversal” to “On (H.460)” under Page 3/3 of the LAN Setup menu.

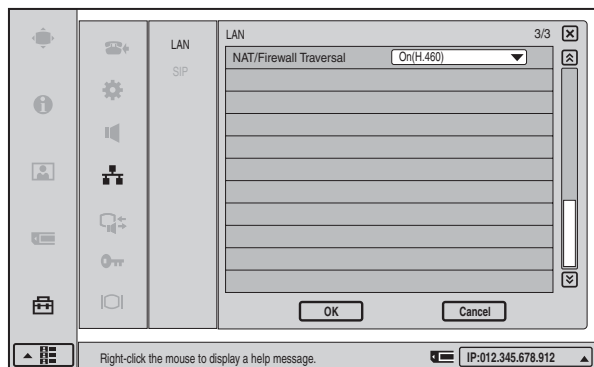

#### Note

You must set up the gatekeeper to use this function.

- 2 Enter a name in “Host Name” under Page 1/3 of the LAN Setup menu, set the “DHCP Mode” to “Off”, and enter the appropriate values for “IP Address”, “Network Mask”, and “Gateway Address”.

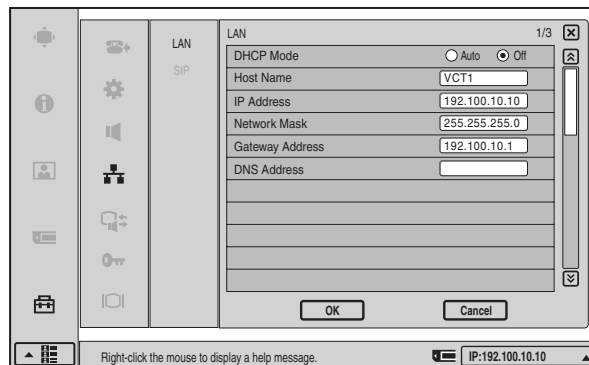

- 3 Set “Gatekeeper Mode” to “On” under Page 2/11 of the Administrator Setup menu, and enter the appropriate values for “Gatekeeper Address”, “User Alias”, and “User Number”.

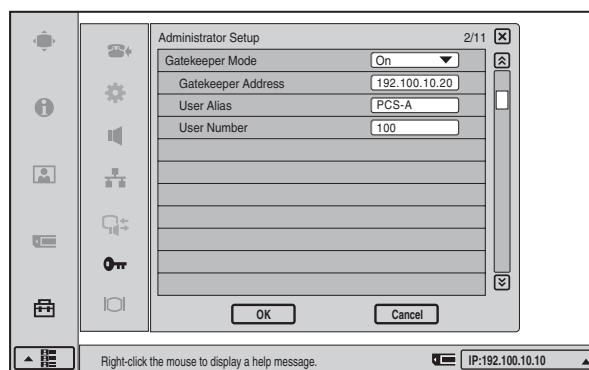

The setting has been configured properly if the correct IP address appears in the launcher menu and “Registration Confirmed” appears under “Gatekeeper” in Page 3/4 of the Status & Info menu.

#### Note

The information that appears in the launcher menu may differ depending on the “Number Display” setting in the Device Setup menu. You can also click the Number Display portion and select the information to display from a list.

## To conduct a video conference

Select “IP” for the line interface, enter the remote party’s IP address in the text box, and dial.

You can set “IP” as the default line interface selection for the launcher menu by setting “Line I/F” to “IP” in the Dial settings of the Communication Mode menu.

*For details on the setting, see “Communication Mode Menu” on page 29.*

## LAN (PPPoE Connections)

When using PPPoE, you can connect via LAN without a router.

A modem (using bridge mode) is required when using FLET'S ADSL.

### Configuration example

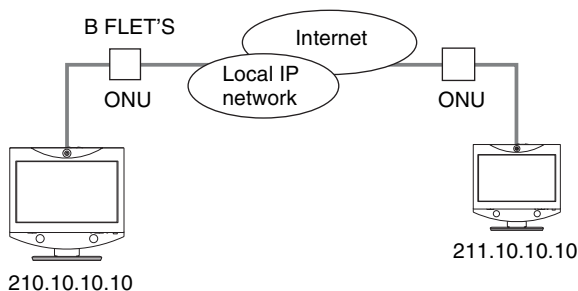

- 1 Set “PPPoE” to “On” under Page 9/11 of the Administrator Setup menu, and enter the PPPoE user name and PPPoE password given to you by the provider.

If you have a fixed IP from the provider, set “Fixed IP for PPPoE” to “On”, and enter your fixed IP address for PPPoE in “Fixed IP Address for PPPoE”.

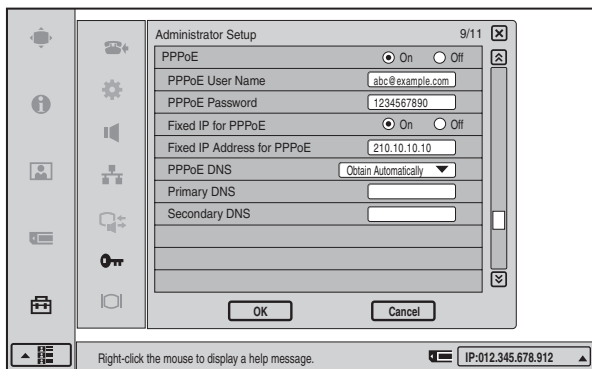

The setting has been configured properly if the correct IP address appears in the launcher menu.

### Notes

- If the fixed DNS server address is specified by the provider, set “PPPoE DNS” to “Specify”, and enter the specific addresses in “Primary DNS” and “Secondary DNS”.
- The information that appears in the launcher menu may differ depending on the “Number Display” setting in the Device Setup menu. You can also click the Number Display portion and select the information to display from a list.

- 2 Remote parties must configure in the same way.

## To conduct a video conference

Select “IP” for the line interface, enter the remote party’s IP address in the text box, and dial.

You can set “IP” as the default line interface selection for the launcher menu by setting “Line I/F” to “IP” in the Dial settings of the Communication Mode menu.

*For details on the setting, see “Communication Mode Menu” on page 29.*

This chapter describes how to conduct a videoconference from start to finish after the administrator has completed various registrations and settings for the system.

This chapter describes how to conduct a point-to-point videoconference via a LAN.

*For use of a “Memory Stick” or optional equipment, see Chapter 4.*

*For information on how to conduct a data conference using the optional PCSA-DSM1 Data Solution Module, see chapter 5.*

*To conduct an encrypted conference via LAN, see Chapter 6.*

*To conduct a videoconference using SIP, see Chapter 7.*

---

## Starting a Conference by Calling a Remote Party

You can start a videoconference with a remote party by dialing. Once you have made a connection to the remote party, you can begin talking just as with a normal phone call and start a videoconference.

*For information on making a call in PC (computer display) mode, see “Calling a Remote Party or Receiving a Call at the PC Screen” on page 89.*

---

## Turning on the Power

- 1 Turn on the power of any equipment to be used for the videoconference.
- 2 Press the  $\text{I} / \text{O}$  (Power) switch on the PCS-TL33.

The indicator of the switch lights up in orange and power to the Video Communication System comes on. When powering on is complete, the indicator lights up in green.

The launcher menu appears on the display and the picture of the local camera is also shown.



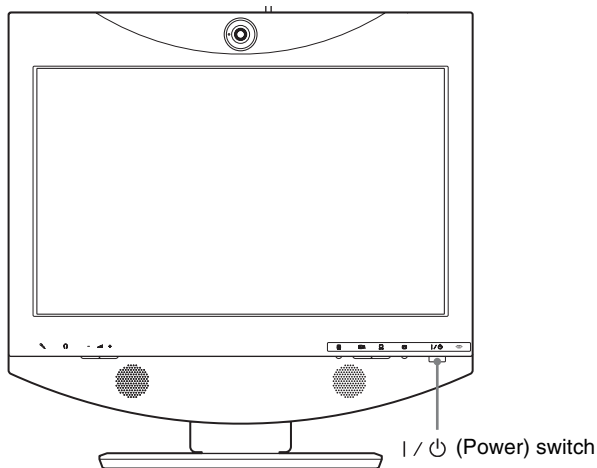

### 3 Make sure that the lens cover of the camera is open.

If it is closed, slide the lever for the lens cover on the top of the system to the right to open the cover. The image from the camera appears on the launcher screen.



## Using the Launcher Menu

The launcher menu appears on the display when the system is turned on or while it is not connected to a remote party. The launcher menu displays the image taken by the local camera, local system status, buttons to open the menus, and the One Touch Dial list.

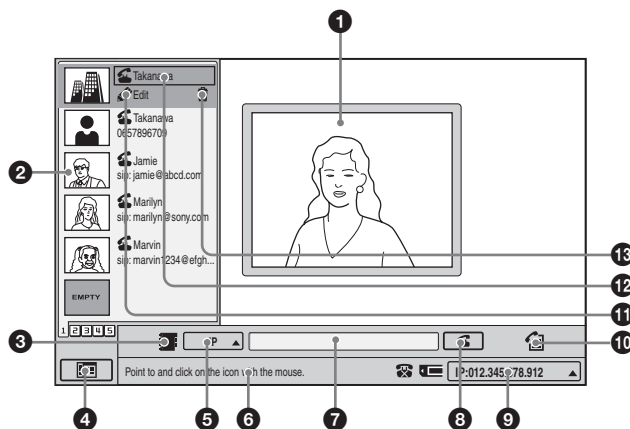

#### 1 Screen

Shows the image from the local camera.

#### 2 One Touch Dial list

When you select an entry from the list with the mouse cursor, buttons appear which let you dial, edit, or delete the entry.

#### 3 Phone Book button

Clicking this button brings up the Phone Book. If a "Memory Stick" containing Private Phone Book data is inserted, the Private Phone Book appears.

#### 4 Menu bar display button

Clicking this button switches between the launcher menu and the setup menu screen.

#### 5 Line I/F selection

Click this to select the line interface to be used when dialing.

#### 6 Message

Messages for operation guidance etc. appear here.

#### 7 Text box

By entering an IP address here, you can connect directly to the respective party.

#### 8 Dial button

Clicking this button dials the number entered in the text box.

#### 9 System status indicators

These indicators show the status of the local system.

☒: The system is set to reject calls.

📀: A "Memory Stick" is inserted.

Number Display: Displays information about the local system's line. The information displayed is determined by the "Number Display" setting in the Device Setup menu. You can also click the Number Display portion and select the information to display from a list.

**10 History button**

Clicking this button brings up the incoming/outgoing call history display.

**11 Edit button**

Clicking this button brings up the List Edit menu for the selected party.

**12 Dial button**

Clicking this button dials the selected party.

**13 Delete button**

Clicking this button removes the selected party from the One Touch Dial list.

**6 Memory stick indicator**

Appears when there is a “Memory Stick” inserted in the memory stick slot.

**7 Mic level indicator**

Shows the microphone input level. When the mic is turned off,  appears instead.

**8 Packet loss indicator**

Shows the LAN line status.

**9 Elapsed time display**

Displays the time elapsed from the start of communication.

**10 Communication control bar display hide button**

By clicking this button, you can switch between hiding and displaying the communication control bar.

: To hide the menu bar.

: To display the menu bar.

**11 DTMF button**

Click this button to display the DTMF soft keyboard.

**Note**

The DTMF button appears when “Display DTMF button” is set to “On” on Page 10/11 of the Administrator Setup menu.

**To display detailed system information**

Click the setup menu bar display button to bring up the menu selection screen. Then click “Status & Info” from the setup menu. The Status & Info menu which shows various information about the local system and communication settings appears.

## Using the Communication Screen

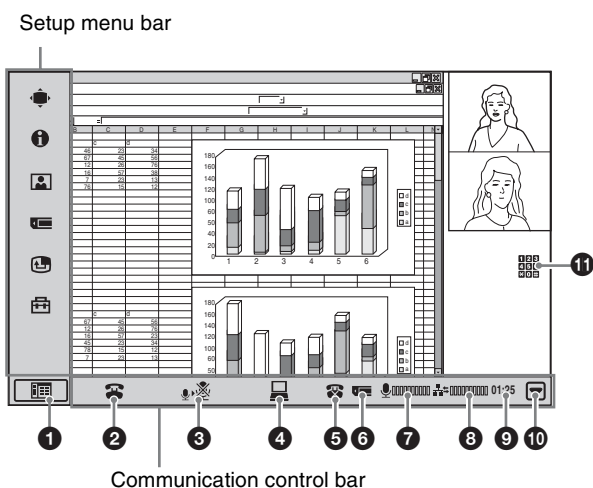
**1 Setup menu bar display button**

By clicking this button, you can switch between hiding and displaying the setup menu bar.

**2 Disconnect button**

Click this button to end a communication.

**3 Mic On/Off button**

Clicking this button turns the mic on or off. The change is reflected in the mic level indicator and the  (Mic Off) button indicator on the main unit as well.

**4 DSM transmission button**

This button is only displayed when a PCSA-DSM1 Data Solution Module is installed.

Click this button to send or cancel data transmissions.

**5 Do not disturb indicator**

Appears when “Do not disturb” in the Answer Setup menu is set to “On”.

## Status & Info Menu

### Note

When communication is not in progress, Page 4/4 appears first and information on the communication status of the previous communication is displayed.

However, as information on previous communications is cleared when the system's power is turned off, this information will not appear when the system is turned on again and no new communications have been held. In such a case, only Page 3/4 and Page 4/4 will appear.

### Page 1/4

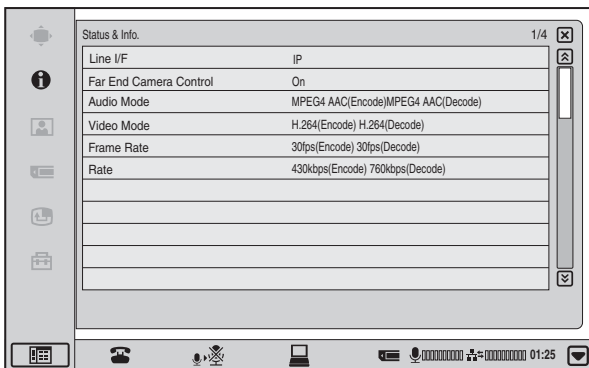

#### Line I/F

Shows the line interface that is being used.

#### Far End Camera Control

Shows whether the far-end camera can be controlled from the system.

#### Audio Mode

Shows the currently selected audio coding methods.

#### Video Mode

Shows the currently selected video coding methods.

### Note

The audio coding methods and video coding methods actually used for communication may be different from the settings shown, depending on the capabilities and settings of the videoconference system at the far end.

#### Frame Rate

Shows the video frame rate in real time.

#### Rate

Shows the actual transmission rate in real time. The rate and then settings are shown for 5 seconds when this page is first shown.

### Page 2/4

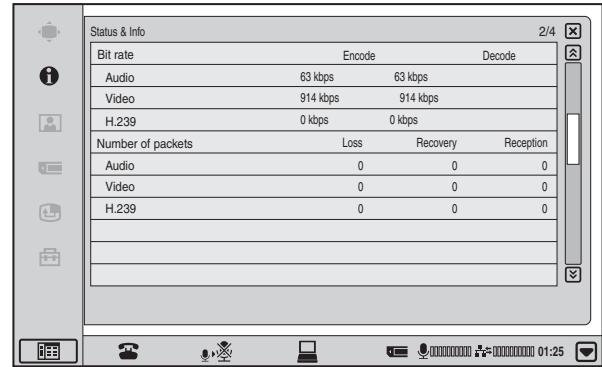

#### Bit rate - Encode

Displays by category (audio, video, and H.239 (Presentation)) the transfer rates for sending data.

#### Bit rate - Decode

Displays by category (audio, video, and H.239 (Presentation)) the transfer rates for receiving data.

#### Number of packets - Loss

Displays by category (audio, video, and H.239 (Presentation)) the number of packets lost during transfer on the network.

#### Number of packets - Recovery

Displays by category (audio, video, and H.239 (Presentation)) the number of lost packets that were recovered with the system's QoS function.

#### Number of packets - Reception

Displays by category (audio, video, and H.239 (Presentation)) the number of packets received during communication.

### Page 3/4

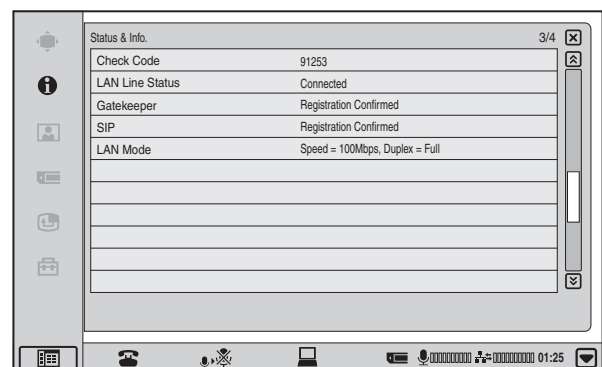

#### Check Code

Shown when H.235 encryption is being used.

#### LAN Line Status

Shows the LAN line status.

**Gatekeeper**

Shows the gatekeeper status.

**SIP**

Shows the SIP status.

**Note**

This appears only when the optional PCSA-SP1 SIP software is installed.

**LAN Mode Speed**

Shows the LAN connection speed.

**LAN Mode Duplex**

Shows whether the LAN connection is in Full duplex or Half duplex.

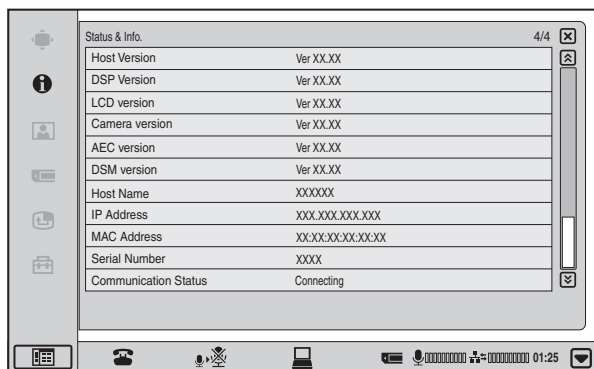
**Page 4/4****Host Version**

Shows the system software version.

**DSP Version**

Shows the software version of the integrated video/audio codec DSP (Digital Signal Processor).

**LCD Version**

Shows the software version of the display panel on the PCS-TL33.

**Camera Version**

Shows the software version of the camera on the PCS-TL33.

**AEC Version**

Shows the version of the acoustic echo canceller.

**DSM Version**

Shows the software version of DSM when the PCSA-DSM1 Data Solution Module is installed.

**Host Name**

Shows the host name.

**IP Address**

Shows the IP address.

**MAC Address**

Shows the MAC address.

**Serial Number**

Shows the serial number of the system.

**Communication Status**

Shows the current communication status of the system.

## Calling a Remote Party Using One Touch Dial

This section describes how to call a remote party that has been registered in the One Touch Dial list.

For information on One Touch Dial registration, see page 42.

- 1 Click the One Touch Dial tab for the party that you want to call.

The One Touch Dial group is switched.



- 2 Move the mouse cursor to the entry that you want to call, and click "Dial".

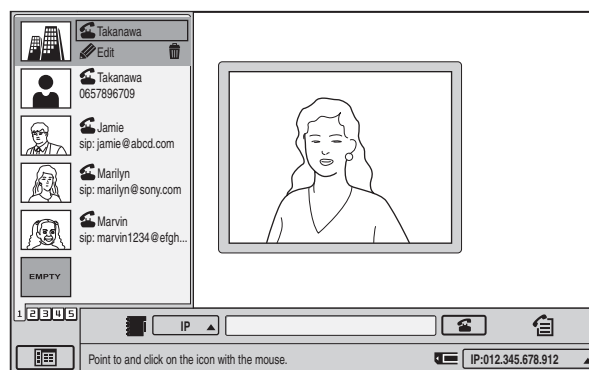

The selected party is called. The indication "Dialing" appears on the display.

When the connection is established, the indication "Communication starts!" appears.

You can now start the videoconference.

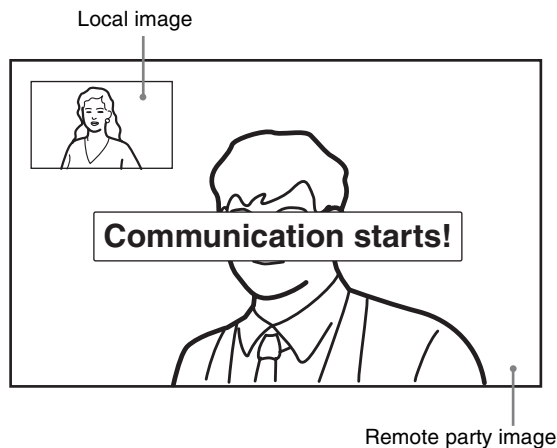

## To cancel dialing before connecting

Click “Cancel”.

## One Touch Dial from the Private Phone Book

Insert the “Memory Stick” in which the Private Phone Book is registered into the Memory Stick slot of the system. The Private One Touch Dial list appears in the launcher menu.

The operations for the Private One Touch Dial list are the same as those for the One Touch Dial list of the system. See “Calling a Remote Party Using One Touch Dial” on page 52.

## Calling a Remote Party by Entering the IP Address in the Launcher Menu

- 1 Select “IP” for the line interface, and enter the IP address of the remote party in the number entry text box.

When you click on the text box, the soft keyboard display appears. Use the display for alphanumeric entry.

### Notes

- Click “Backspace” to delete the character immediately before the cursor.
- Click “Delete all” to delete the entire entry and start over.

- 2 Click (Dial).

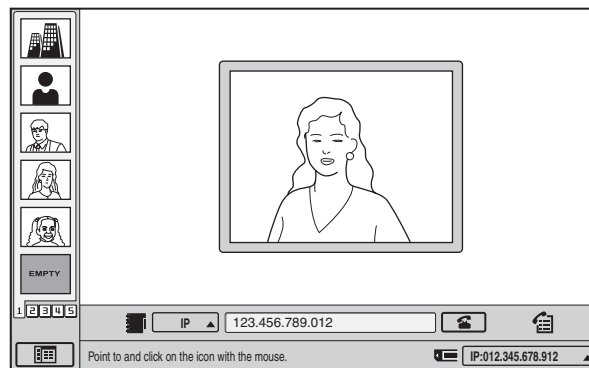

The entered party is called. The indication “Dialing” appears on the display.

When the connection is established, the indication “Communication starts!” appears.

You can now start the videoconference.

## To cancel dialing before connecting

Click “Cancel”.

## Calling a Remote Party Registered in the Phone Book

This section describes how to call a remote party that has been registered in the Phone Book.

*For information on Phone Book registration, see page 38.*

- 1 Click (Phone Book) in the launcher menu.

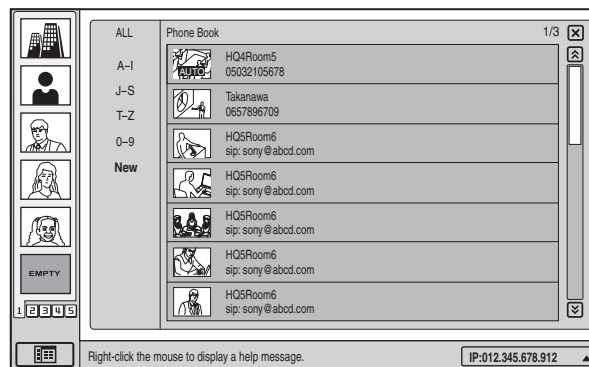

The Phone Book menu appears.

- 2 Move the mouse cursor to the entry that you want to call, and click “Dial”.

The selected party is called. The indication “Dialing” appears on the display.

When the connection is established, the indication “Communication starts!” appears.

You can now start the videoconference.

### To cancel dialing before connecting

Click “Cancel”.

### To call a remote party registered in the Private Phone Book

- 1 Insert the “Memory Stick” on which the Private Phone Book is stored into the Memory Stick slot of the system.

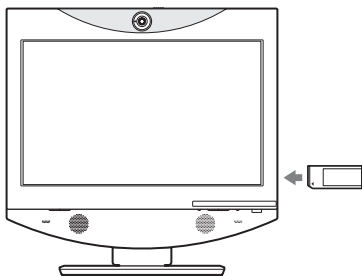

The Phone Book contents are switched to the Private Phone Book.

- 2 Move the mouse cursor to the entry that you want to call, and click “Dial”.

The selected party is called.

#### Note

If the “Auto Dial” item for the Private Phone Book is set to “On”, the system automatically dials the specified entry when the “Memory Stick” is inserted. For information on specifying an entry, see “To dial a specified entry of the Private Phone Book automatically” on page 40.

### To search for an entry in the Phone Book

The Phone Book displays seven entries at a time.

When you select the “ALL” tab, the first seven entries of the Phone Book are shown.

When you select the “0-9”, “A-I”, “J-S”, or “T-Z” tab, the first seven entries starting with the respective letter or numeral are shown.

When there are several pages, a scroll bar will appear at the right side of the screen. To advance to the next page, click the Page button at the bottom of the scroll bar. To go back to the previous page, click the Page button at the top of the scroll bar.

You can also scroll through pages by moving the scroll bar with the mouse.

## Calling a Remote Party From the Incoming/Outgoing Call History

This section describes how to call a remote party from the History list.

- 1 Click  (History) in the launcher menu.

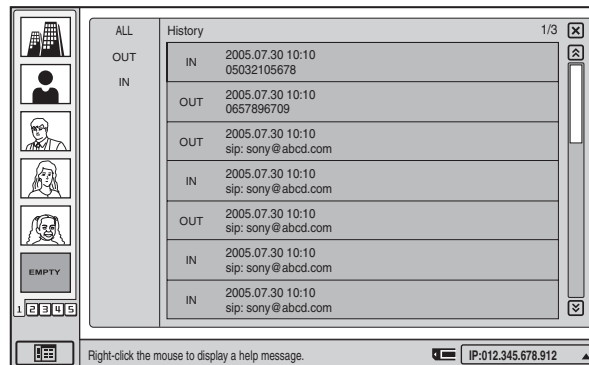

The History menu appears.

- 2 Move the mouse cursor to the entry that you want to call, and click “Dial”.

The selected party is called. The indication “Dialing” appears on the display.

When the connection is established, the indication “Communication starts!” appears.

You can now start the videoconference.

### To cancel dialing before connecting

Click “Cancel”.

# Receiving a Call From a Remote Party

Operations for answering a call differ depending on the setting of the answer mode.

## Auto answer mode

The system automatically receives a call from a remote party and you can start conferencing. Although no operation is necessary to start, the picture on the local site will be displayed on the remote site screen even if you are not ready to begin.

## Manual answer mode

When there is an incoming call, a ringer tone sounds. You need to connect the call manually before starting the conference.

You can start it whenever you are ready.

### Note

You cannot answer the call unless the system is turned on.

*For setting of the answer mode, see “Auto Answer” and “Videoconference Button Answer” in the “Answer Setup Menu” on page 25.*

*For information on receiving a call in PC mode, see “Calling a Remote Party or Receiving a Call at the PC Screen” on page 89.*

## Answering a Call From a Remote Party

### To answer a call in auto answer mode

When you receive a call, a ringer tone sounds and the message “Answering” appears on the display.

The system is automatically connected and the picture of the remote party is displayed on the local system and the sound is heard. The picture and sound on the local site will be enabled on the remote site at the same time.

The message “Communication starts!” appears on the display. You are now ready to start a conference.

### Notes

- If you receive a call when you are using the Video Communication System as a computer display, the picture of the remote party will appear automatically as a window picture.

- See pages 57 - 60 to adjust the sound and picture during the conference.

### To receive a call in manual answer mode

When you receive a call, a ringer tone sounds and the message “Incoming call. Answer?” appears on the display.

Click “OK”.

The system is then connected.

Once the connection is established, the picture of the remote party is displayed on the local system and the sound is heard. The picture and sound from the local system will be transmitted to the remote site at the same time.

The message “Communication starts!” appears on the display.

You are now ready to start a videoconference.

You can also connect the call by pressing the  (Videoconference) button on the unit when “Videoconference Button Answer” is set to “On” in the Answer Setup menu.

### Note



For information on how to adjust the sound and camera during a videoconference, see pages 57 - 60.

### When you do not want to answer the call

Click “Cancel”. The ringer tone stops.

You can also reject the call by pressing the  (PC) button on the unit when “Videoconference Button Answer” is set to “On” in the Answer Setup menu.

### Note

When you reject a call using the  (PC) button on the unit, the screen switches to PC mode. To return to the previous screen, press the  (Videoconference) button on the unit.

### To display the elapsed communication time

You can show the elapsed communication time on the display if the “Time Display” item in the Device Setup menu is set to “On”.

To disable this function, set the item to “Off”.

*For information on the “Time Display” item, see the section “Device Setup Menu” on page 25.*

## Ending the Conference

- 1 Click the  (Disconnect) button.  
The indication “Disconnect?” appears on the display.
- 2 Click “OK”.



The line is disconnected.

**Note**

The power of the system remains on even if the line is disconnected.

**To cancel disconnection of the system**

Click “Cancel”.

**To register the connected remote party in the Phone Book**

You can easily register the remote party who has just disconnected.

If the “Last Number Registration” item in the Device Setup menu is set to “On”, the message “Register this participant in the list?” appears after a videoconference with an unregistered remote party is finished. When you click “OK”, the Edit List menu appears.

**Notes**

- If the “Last Number Registration” item is set to “Off”, the message “Register this participant in the list?” does not appear.
- If a “Memory Stick” containing Private Phone Book data is inserted, the entry will be saved in the Private Phone Book.
- If you do not click “OK” when the message appears, the message will disappear after about 30 seconds, and the remote party will not be registered to the list.

*For information on the “Last Number Registration” item, see the section “Device Setup Menu” on page 25.*

# Joining a Multipoint Videoconference

The PCS-TL33 can join a multipoint videoconference as the child terminal to an MCU (Multipoint Control Unit). The procedures for initiating and accepting calls are the same as for a point-to-point videoconference. For details, see the sections “Starting a Conference by Calling a Remote Party” on page 48 and “Receiving a Call From a Remote Party” on page 55.

**Note**

Because the PCS-TL33 does not feature the MCU function, this system cannot be used to host a multipoint videoconference.

## About broadcast mode

When participating in a multipoint videoconference, the video from the local system can be broadcast to all other participants.

To do this, click “Broadcast Mode” at the bottom of the menu bar, and then click “Start” in the Broadcast Mode menu.

The  indicator appears at the bottom right of the screen during broadcast.

To stop broadcasting, click “Stop” in the Broadcast Mode menu.

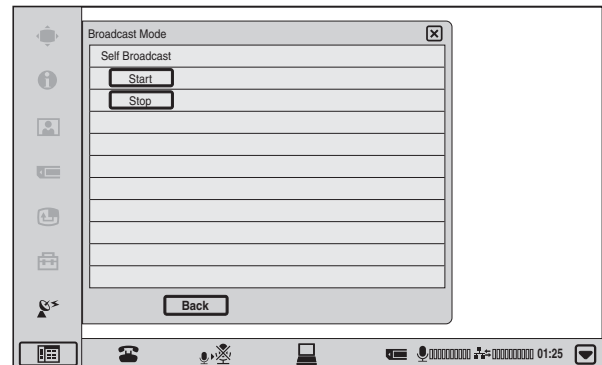

**Note**

To close the Broadcast Mode menu during broadcast, click the “Back” or  button. To stop broadcasting, open the Broadcast Mode menu again by clicking “Broadcast Mode” at the bottom of the menu bar, and click “Stop”.



# Adjusting the Picture and Sound

## Adjusting the Picture Quality

For details on the adjustment steps, see the section “Adjusting the Picture Quality on the Display” on page 89.

## Adjusting the Volume

You can adjust the volume of the sound to be heard during a videoconference.

Press the  $\triangle$  (Volume) + button on the PCS-TL33 to increase the volume, and the  $\triangle$  (Volume) – button to decrease it.

You can adjust the volume separately for a videoconference and for computer display, and store the respective settings.

### Note

If increasing the volume results in acoustic feedback, decrease the volume setting.

## Cutting Off the Sound Momentarily - Mic Off Function

You can momentarily cut off the sound to be sent to the remote party.

To do this, either press the  $\text{M}$  (Mic Off) button on the PCS-TL33, or click  $\text{M}$  (Off) on the display. The sound of the local system will not be heard by the remote party.

### To restore the sound

Press the  $\text{M}$  (Mic Off) button on the PCS-TL33 again, or click  $\text{M}$  (On) on the display.

## Cutting Off the Sound On Answering - Mic Off Function

You can cut off the sound to be sent to a remote party when you have answered a call from the remote party.

To do this, set the “Mic on Answer” item in the Answer Setup menu to “Off”. Only the picture of the local system will be sent to the remote party when answering a call.

For details on the “Mic on Answer” setting, see the section “Answer Setup Menu” on page 25.

### To send the sound to the remote party

Press the  $\text{M}$  (Mic Off) button on the PCS-TL33 again, or click  $\text{M}$  (On) on the display.

## Synchronizing Audio and Video - Lip Sync Function

During a videoconference, a time lag may occur between the sound and picture sent to the remote party.

When you activate the Lip Sync function, the system automatically adjusts the synchronization of audio and video. However, this may delay the overall transmission somewhat, because the audio will be delayed to match the video.

To activate the Lip Sync function, set the “Lip Sync” item in the Communication Mode Setup menu to “On”.

For details on the “Lip Sync” setting, see the section “Communication Mode Menu” on page 29.

### Note

If there is an audio/video synchronization problem in the signal sent from the remote party, you have to ask the remote party to enable the Lip Sync function at their end.

## Reducing Echo - Echo Canceller

The system is equipped with an Echo Canceller function designed to reduce the echo that can occur during bidirectional audio transmission.

# Adjusting the Camera

You can adjust the image shot by the local camera that is sent to the remote party to obtain the desired angle and size.

During communication you can also control the camera on the remote site to adjust the image shot by the remote camera.

## Adjusting the Zoom and Camera Angle

The zoom and angle can be adjusted from the Camera Control menu, the camera image during communication, or the launcher screen when communication is not in progress.

## Adjusting the display using the Camera Control menu

The remote camera can only be adjusted during communication.

If the focus adjustment buttons appear on the remote camera adjustment screen, you can adjust the focus.

- 1 On the menu selection screen, click “Camera Control”.

The Camera Control menu appears.

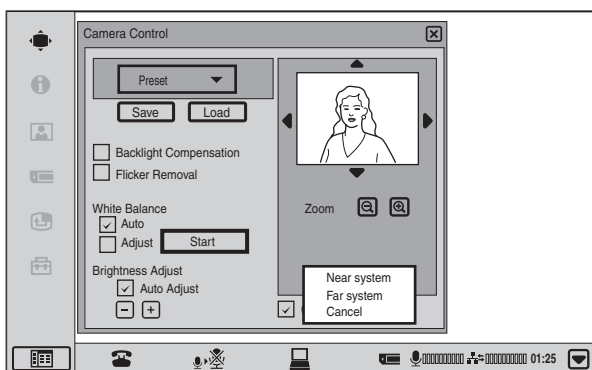

- 2 Select the camera you want to control (“Near system” or “Far system”).
- 3 To zoom the image, click the or button under the image.
- 4 Click the /// symbols at the image edges to adjust the camera angle.
- 5 If you selected to control the remote camera, click the / buttons to adjust the focus.

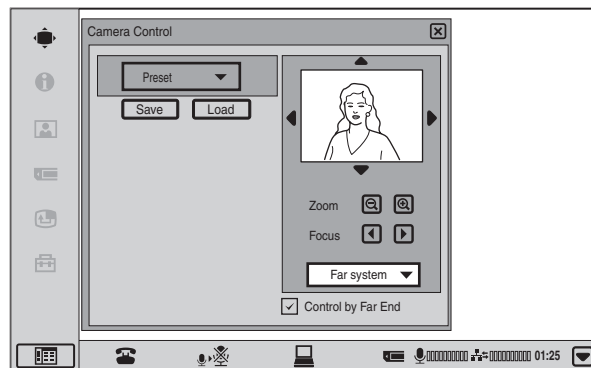

- 6 Click or the menu bar.

The Camera Control menu closes.

### Notes

- When controlling a remote camera, “Far End Camera Control” must be set to “On” in the Communication Mode menu of the local system, and the remote system must be set to receive camera control commands. For details on setting the remote system, refer to the operating instructions for each device.
- You cannot control the remote camera during a session if the remote control format of the remote camera is not H.281. If you cannot control the remote camera, ask the remote party about the remote control format of their camera.
- If the local and remote parties try to control the same camera at the same time, the camera may not operate correctly.

## Adjusting the display during communication







- 1 Right-click on the local or remote image.

Zoom and angle buttons appear on the display.

### Note

When the image is from the local camera, a (Backlight compensation) button appears. Each click of this button toggles the backlight compensation function on and off.



- 2 To zoom the image, click the  or  button under the image.
- 3 Click the , , , or  symbols at the image edges to adjust the camera angle.

When you right-click the camera image window, the zoom and angle adjustment buttons disappear and the launcher screen appears again.

## Adjusting the display using the launcher menu when communication is not in progress

As described above, right-click the camera image. Zoom and angle buttons will appear on the display. Perform the adjustment in the preceding section.

### Note

If the lens cover is closed, camera adjustment is not possible.

## Accepting Remote Camera Control

Deselect the “Control by Far End” check box in the Camera Control menu to reject control of the camera by the remote party.

### Note

Select whether to adjust the remote camera in “Far End Camera Control” under “Dial” of the Communication Mode menu.

## Adjusting the Brightness



The brightness can be adjusted with the Camera Control menu.



Normally, the brightness is automatically adjusted to obtain an optimum level. You can also adjust it manually. It is recommended that the brightness be adjusted automatically.

### Note

Only the brightness of the local camera can be adjusted.

### To adjust the brightness

To manually adjust the brightness, deselect the “Auto Adjust” check box of the “Brightness Adjust” item, and then click the  or  button.

Click  to brighten the image or  to darken it.

### To shoot the picture with backlight compensation

Use backlight compensation when shooting a subject against a bright background.

To activate backlight compensation, select the “Backlight Compensation” check box.

For the local camera, backlight compensation can also be switched on and off by clicking , which appears when making camera adjustments during communication or from the launcher menu.

### Note

If “Auto Adjust” is not selected for “Brightness Adjust”, backlight compensation will not function.

### To eliminate flicker

If a fluorescent lamp is connected to the same power source as the PCS-TL33, flicker may occur in the camera picture.

To eliminate the flicker, select the “Flicker Removal” check box.

### Using a fixed white balance setting

In the default condition, white balance is adjusted automatically.

If you want to adjust white balance manually, select the “Adjust” check box. While draping something white, such as a piece of paper, in front of the camera, click “Start” and set the white balance to fit the ambient environment. The white balance will then be fixed to that setting.

### To release the fixed setting

Select the “Auto” check box under “White Balance”.

## Presetting the Zoom and Angle Settings

Up to six preset settings for zoom and camera angle can be registered in the Camera Control menu. Once you have stored the settings, you can easily recall them to move the camera.

- 1 In the Camera Control menu, under “Preset”, click the desired number (1 - 6).

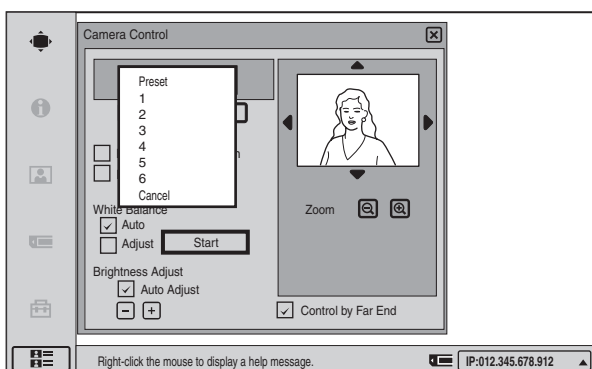

### Note

During a communication session, you can select the remote camera.

*For information on how to bring up the Camera Control menu and selecting a camera, see “Adjusting the Zoom and Camera Angle” on page 58.*

- 2 Adjust the zoom and angle.

*For information on how to make the adjustment, see “Adjusting the Zoom and Camera Angle” on page 58.*

- 3 Click “Save”.

The setting is registered in the selected preset number.

## Recalling a Preset Zoom and Angle Setting

You can use the Camera Control menu to recall a preset zoom and camera angle setting.

- 1 In the Camera Control menu, under “Preset”, click the desired number (1 - 6).

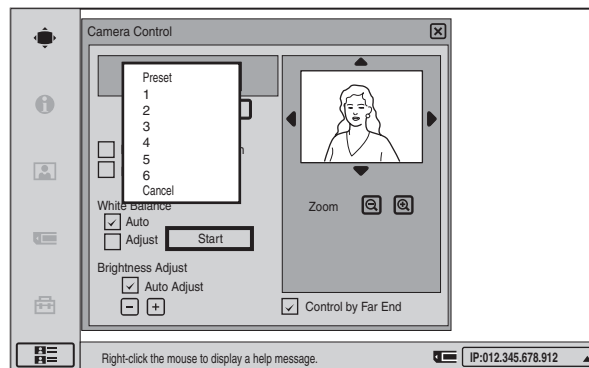

### Note

During a communication session, you can select the remote camera.

*For information on how to bring up the Camera Control menu and selecting a camera, see “Adjusting the Zoom and Camera Angle” on page 58.*

- 2 Click “Load”.

The setting of the preset number is recalled and the camera moves to the position of that setting.

### About stored adjustment settings

The PCS-TL33 retains the settings for camera zoom and angle, brightness, backlight compensation on/off and flicker on/off in non-volatile memory.

When you turn off the system and turn it on again, the camera will be adjusted using the stored settings.

# Changing the Screen Layout

During a communication session, you can use the Screen Layout Setup menu to control the way video is shown on the display.

## Bringing up the Screen Layout Setup Menu

- 1 During a communication session, click the menu bar display button.

The menu bar appears.

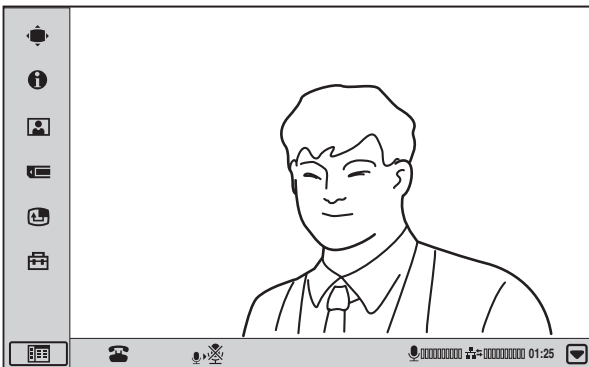

- 2 In the menu bar, click  (Screen Layout Setup).

The Screen Layout Setup menu appears.  
The screen changes when you select a screen layout.

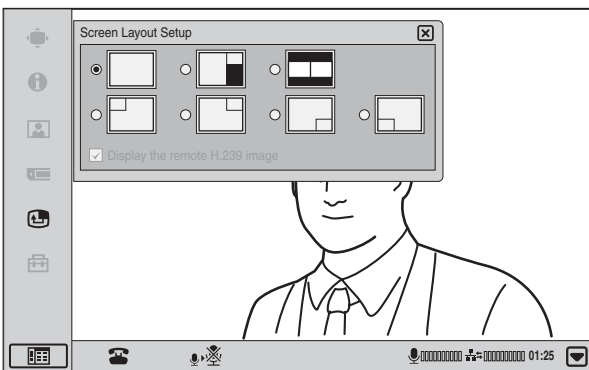

## Switching the Display

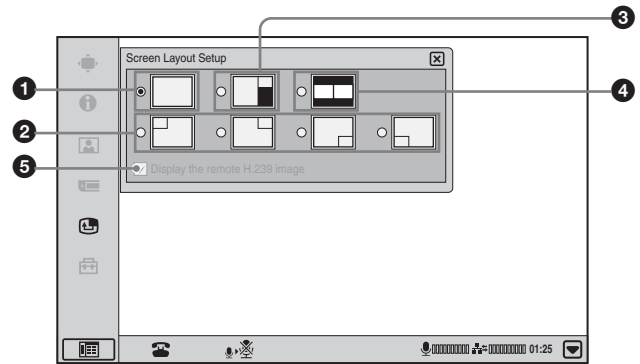

- 1 Full screen



Only the remote video is shown as a full-screen display. When still images are sent or received, presentation data is received, or the  (PC) button is pressed to display the computer screen, the display switches to Picture-and-Picture mode. The transmitted or computer images are shown as full-screen displays, with the remote video and local video shown as window pictures.

When the “Display the remote H.239 image” check box is not selected, however, presentation data that is received will not display on the unit’s screen.

- 2 Picture-in-Picture



The remote video is shown as a full-screen display and the local video as a window picture. When still images are sent or received, presentation data is received, or the  (PC) button is pressed to display the computer screen, the transmitted or computer images are shown as full-screen displays, with the remote video shown as a window picture.

The display position of the window picture can be set to top left, top right, bottom right, and bottom left.

When the “Display the remote H.239 image” check box is not selected, however, presentation data that is received will not display on the unit’s screen.

### 3 Picture-and-Picture



The remote video is shown as a full-screen display on the left and the local video as a window picture on the right. When still images are sent or received, presentation data is received, or the  (PC) button is pressed to display the computer screen, the transmitted or computer images are shown as full-screen displays, with the remote video and local video shown as window pictures.

When the “Display the remote H.239 image” check box is not selected, however, presentation data that is received will not display on the unit’s screen.

### 4 Side-by-side



The remote video is shown on the left and the local video on the right, at the same size. When still images are sent or received, presentation data is received, or the  (PC) button is pressed to display the computer screen, the transmitted or computer images are shown on the left and the remote video on the right.

When the “Display the remote H.239 image” check box is not selected, however, presentation data that is received will not display on the unit’s screen.

### 5 Display the remote H.239 image

This check box can be selected when a PCSA-DSM1 Data Solution Module is installed on the unit.

When this check box is not selected, presentation data that is received is output only from the RGB OUT on the Data Solution Module. In such a case, you can display the remote video on the unit’s screen in full-screen (on the left side during side-by-side display).

This chapter describes the various videoconferences using the optional equipment in addition to the components contained in the PCS-TL33 Video Communication System.

*For information on conducting a data conference using the optional PCSA-DSM1 Data Solution Module, see Chapter 5.*

---

## Using Still Images Stored in a “Memory Stick” for a Videoconference

You can display the still images stored in the optional “Memory Stick” or transmit them to a remote party.

---

### Displaying a Still Image Stored on a “Memory Stick”

- 1 Insert the “Memory Stick” containing the still images into the Memory Stick slot on the Video Communication System.

Insert the “Memory Stick” with the front facing you and in the direction of the arrow on it.

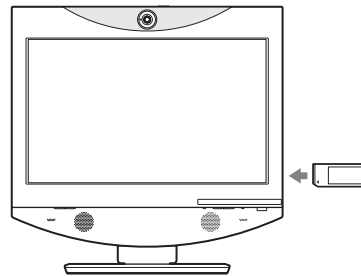

- 2 Display the Image viewer menu.

Click the menu bar display button to bring up the menu selection screen. Then click “Image viewer”.

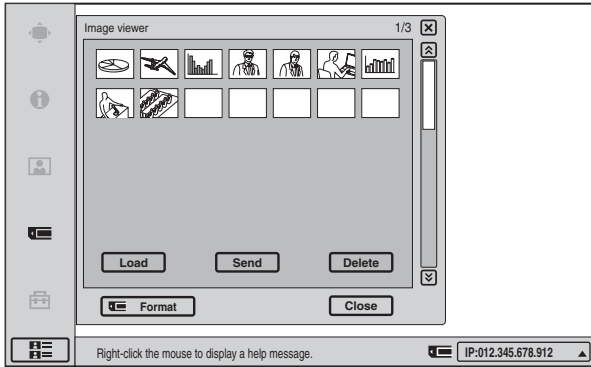

- 3 Select the still image you want to display, then click “Load”.

The menu disappears and the selected still image is displayed.

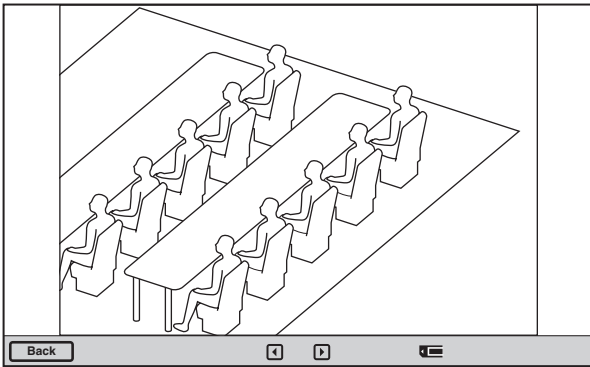

#### To display a different image

While a still image is displayed, you can click ◀ to return to the previous image or ▶ to go to the next image.

#### To delete a still image

On the Image viewer menu, select the image you want to delete, and click “Delete”. Click “OK” when the message “Delete File?” appears. The selected still image is deleted from the “Memory Stick”.

#### To remove the “Memory Stick”

Carefully push the “Memory Stick” in. This causes it to pop out slightly, and you can then remove it.

## Sending a Still Image Stored on a “Memory Stick”

During a communication session, you can send still images stored on a “Memory Stick” to the remote party.

- 1 Insert a “Memory Stick” into the Memory Stick slot on the Video Communication System, and display the Image viewer menu.

*For information on how to insert a “Memory Stick” and how to display the Image viewer menu, see “Displaying a Still Image Stored on a “Memory Stick”” on page 63.*

- 2 Select the still image you want to send, and click “Send”.

The selected still image is displayed, and is sent to the remote party. The message “The still image has been sent.” appears on the display.

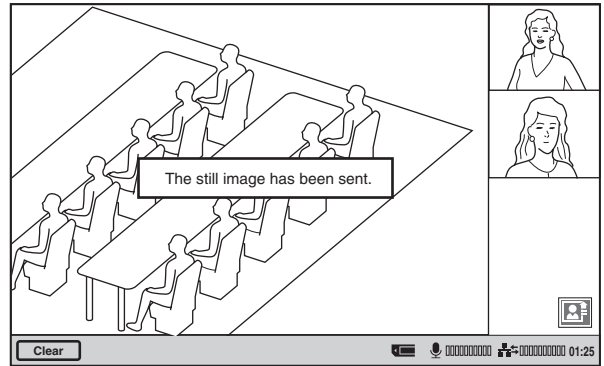

#### To cancel still image display

Click “Clear”.



# About “Memory Stick”

## What is “Memory Stick”?

“Memory Stick” is a compact, portable and versatile IC (Integrated Circuit) recording medium with a data capacity that exceeds a floppy disk. “Memory Stick” is specially designed for exchanging and sharing digital data among “Memory Stick” compatible products. Because it is removable, “Memory Stick” can also be used for external data storage.

“Memory Stick” is available in two sizes: standard size and compact “Memory Stick Duo” size. Once attached to a Memory Stick Duo adapter, “Memory Stick Duo” turns to the same size as standard “Memory Stick” and thus can be used with products compliant with standard “Memory Stick.”

## Types of “Memory Stick”

There are five types of “Memory Stick” depending on various uses.

- “Memory Stick PRO”  
The “Memory Stick PRO” is a “Memory Stick” that allows faster data transfer rates in devices that support it. It also incorporates MagicGate copyright protection technology.
- “Memory Stick-R”  
Data stored in this type of “Memory Stick” is not overwritten. It can be used only with equipment compatible with “Memory Stick-R”. Data that requires MagicGate copyright protection technology cannot be stored on this type.
- “Memory Stick”  
Any type of data except copyright-protected data that requires MagicGate copyright protection technology can be stored.
- “MagicGate Memory Stick”  
Equipped with the MagicGate copyright protection technology.
- “Memory Stick-ROM”  
Stores pre-recorded, read-only data. Recording or erasing data cannot be done with this type.
- “Memory Stick” (with memory select function)  
Equipped with multiple memories (128 MB). You can select the memory to use with the memory select switch on the back of the “Memory Stick”. You cannot use different memories simultaneously or continuously.

## Available types of “Memory Stick” for the unit

You can use “Memory Stick PRO”, “Memory Stick”, and “MagicGate Memory Stick” with the unit. However, because the unit does not support the MagicGate

standards, data recorded with the unit is not subject to MagicGate copyright protection.

## Notes on “Memory Stick Duo”

- To use “Memory Stick Duo” with this unit, attach it to the Memory Stick Duo adapter before inserting it into the unit.
- Be sure to attach “Memory Stick Duo” to the adapter with the correct orientation.
- Be sure to insert the Memory Stick Duo adapter with the correct orientation. Otherwise, the unit may be damaged.
- Do not insert the Memory Stick Duo adapter without “Memory Stick Duo” attached. Doing so may result in malfunction of the unit.

## What is MagicGate?

MagicGate is copyright protection technology that uses encryption technology.

## Format that can be displayed with this unit

The unit can display the picture files recorded on a “Memory Stick” in the following format:

- Image files (DCF-compatible) compressed in the JPEG (Joint Photographic Experts Group) format (extension: .jpg)
- Image files of up to 2048 × 1536 pixels can be displayed.

### Note

Progressive JPEG is not supported.

## Before using a “Memory Stick”

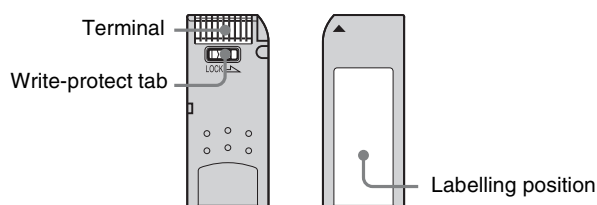

- When you set the “Memory Stick” write-protect tab to “LOCK,” data cannot be recorded, edited, or erased.
- Use a sharp object, such as a ballpoint pen, to move the “Memory Stick Duo” erasure prevention switch.
- Data may be damaged if:
  - You remove the “Memory Stick” or turn off the unit while it is reading or writing data.
  - You use the “Memory Stick” in a location subject to the effects of static electricity or electric noise.

**Notes**

- Do not attach any other material than the supplied label onto the label space.
- Attach the label so that it does not stick out beyond the labelling position.
- Do not write forcefully on the “Memory Stick Duo” memo area.
- Carry and store the “Memory Stick” in its case.
- Prevent metallic objects or your finger from coming into contact with the metal parts of the connecting section.
- Do not strike, bend, or drop the “Memory Stick.”
- Do not disassemble or modify the “Memory Stick.”
- Do not allow the “Memory Stick” to get wet.
- Do not use or store the “Memory Stick” in a location that is:
  - extremely hot, such as in a car parked in the sun.
  - under direct sunlight.
  - very humid or subject to corrosive substances.

- “Memory Stick Duo” and MEMORY STICK DUO are trademarks of Sony Corporation.
- “Memory Stick” and  are trademarks of Sony Corporation.
- “MagicGate Memory Stick” and MAGICGATE are trademarks of Sony Corporation.
- “Memory Stick-ROM” and MEMORY STICK-ROM are trademarks of Sony Corporation.
- “Memory Stick PRO” and MEMORY STICK PRO are trademarks of Sony Corporation.
- “Memory Stick-R” and MEMORY STICK-R are trademarks of Sony Corporation.

**Formatting a “Memory Stick”****Notes**

- A “Memory Stick” formatted with a computer cannot be guaranteed on the Video Communication System. Make sure to use a “Memory Stick” that has been formatted with this system.
- If you format a “Memory Stick”, all data, including the still images and Phone Book, will be lost.
- Depending on the type of “Memory Stick” used, it may take a few moments before the “Memory Stick” is ready for use after it is inserted.

**To format a “Memory Stick”**

Click “Memory Stick Format” in the Image viewer menu. The message “Format a Memory Stick?” appears. When you click “OK”, the “Memory Stick” will be formatted.

**Sending Motion Pictures as Still Images**

You can send motion pictures shot by the Camera as still images.







When you are sending pictures that contain lots of text during a video conference, it is recommended that you send them as still images. The images become clearer than motion pictures and the texts are easy to read.

**Sending Still Images Using the Still Image Menu**

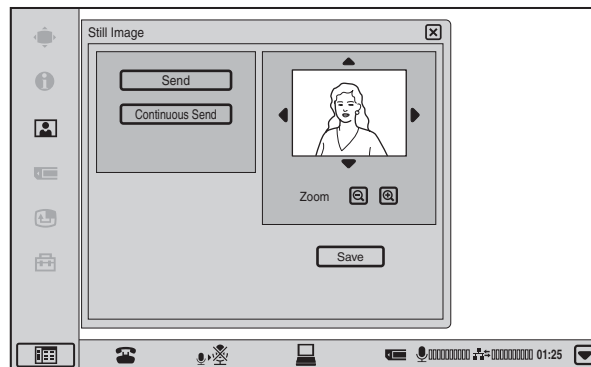
While in communication with the remote party, you can send motion pictures shot by the local camera as still images. You can send one still image or still images continuously.

**1** Display the Still Image menu.

Click the menu bar display button to bring up the menu selection screen. Then click “Still Image”.

**2** Adjust the camera zoom and angle.**3** To zoom the image, click the  or  button under the image.**4** Click the , , , or  symbols at the image edges to adjust the camera angle.**5** Click “Send” or “Continuous Send”.

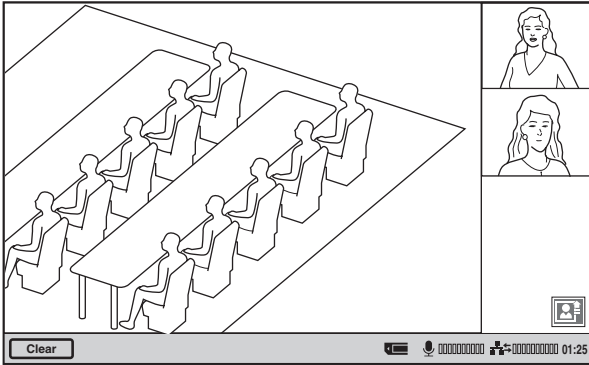

The local display freezes, and a still picture will be sent to the remote party.  
 If you select “Send”, a single image is sent. When transmission is finished, the message “The still image has been sent.” appears.  
 If you select “Continuous Send”, still images are sent continuously. The sending interval depends on the transmission rate and the image type.

### To stop “Continuous Send”

Click “Clear”.

### To cancel still image display

Click “Clear”.

## Receiving Still Images

When you receive a still image from a remote party, the image is shown as a full-screen display.  
 Click “Save” to save the still image to a “Memory Stick”, and click “Clear” to return to the communication screen.

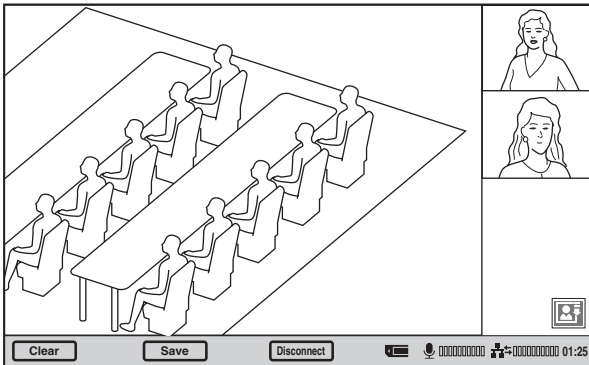

## Receiving Whiteboard Images

When a remote party is using a whiteboard during a videoconference, whiteboard images received from the remote party are shown in full-screen display.  
 Click “Save” to save received whiteboard images to a “Memory Stick.”

You can return to the normal communication screen by clicking “Back”. To display the whiteboard image again, click the  (Whiteboard) icon.

The  (Whiteboard) icon appears on the bottom right of the communication screen only when receiving whiteboard images.

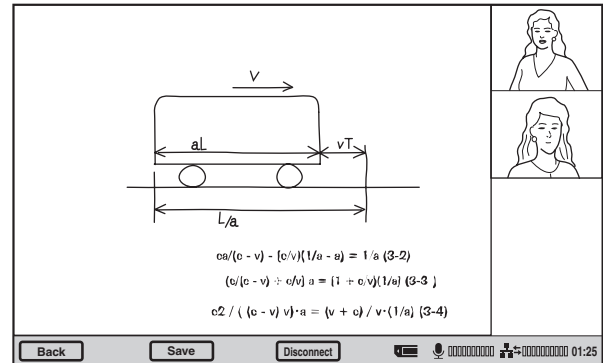

## Saving Still Images

When a “Memory Stick” is inserted beforehand, you can easily store still images sent from the remote party or still images from the local camera onto the “Memory Stick”. You can use the saved images for One Touch Dial buttons and Phone Book.

### Saving Remote Party Pictures Automatically – Automatic Image Capture Feature

The system automatically captures still images of the remote party ten times every five seconds from the beginning of each communication, and saves them in the built-in memory. The still images stored in the memory are retained until the next communication starts or the power of the system is turned off.

This feature is activated when the “Memory Stick” is not inserted.

Stored images can be used as thumbnail images for One Touch Dial and the Phone Book.

#### Note

If it has taken a long time from dialing to establish the connection, the first captured images may be black. This is not a problem.

### Saving Still Images Using the Still Image Menu

**1** Display the Still Image menu.

Click the menu bar display button to bring up the menu selection screen. Then click “Still Image”.

**2** Click “Save”.

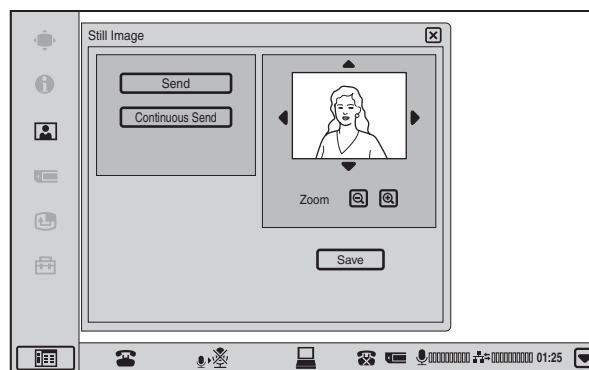

The picture on the display will be saved on the “Memory Stick” as a still image.

#### Notes

- Do not remove the “Memory Stick” until the data is completely loaded. If you do, the “Memory Stick” may be damaged or the system may cause a malfunction.
- A still image file is saved as a new file. It will not be overwritten.

#### When the write-protect tab on the “Memory Stick” is set to “LOCK”

The message “Memory Stick write-protected” appears and you cannot save the still image file.

#### When the memory of the “Memory Stick” is full

The message “Memory Stick full.” appears and you cannot save the still image file.

#### Image format that can be stored in a “Memory Stick”

##### File name

The image file is saved under the directory named “\DCIM\100MSDCF” with a file name as “DSCXXXXX.JPG”.

##### Compression format

This system compresses and records the recorded image data in the JPEG (Joint Photographic Experts Group) format. The file extension is “.jpg”.

#### Notes

- This system is not compatible with progressive JPEG format data.
- If a folder named with a larger number than 100 exists, the image file is saved in that folder.

## Using External Microphone and Headphones

The built-in microphone of the PCS-TL33 is designed for individual use. The optional external microphones PCS-A1 or PCSA-A3 can also be connected. A pair of headphones or a headset can also be used.

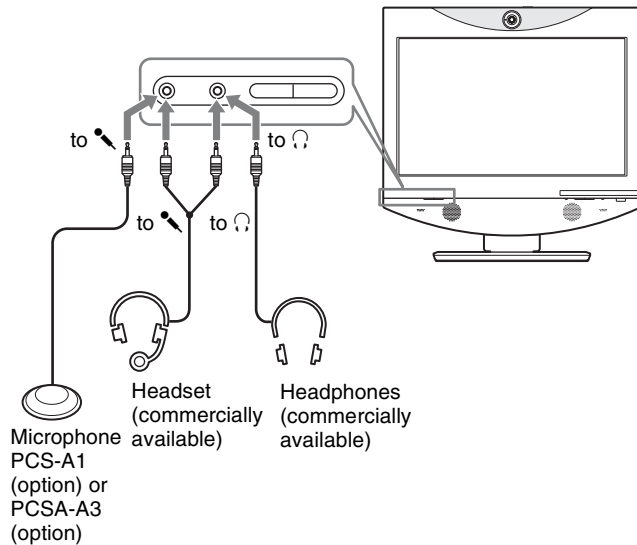

### Notes

- The built-in microphone is disabled when an external microphone is connected.
- The built-in speakers are disconnected when headphones are connected.

### Notes on installation of the microphones

- Install an external microphone more than 1 m (3.3 feet) away from this system.
- Keep the microphone about 50 cm (19 3/4 inches) away from the participants.
- Place the microphone in a quiet, echo-free location.
- Install the microphone away from equipment that may cause noise.
- Avoid covering a microphone with paper, etc., or moving it. If you do either, extreme noise and echo may be heard temporarily by the remote party.



## Controlling the Remote System With Tone Signals - DTMF Transmission

When dialing, tone signals (DTMF: Dual Tone Multi Frequency) assigned to the numbers for (0-9,#,\*) can also be sent. Some systems are designed to allow remote control using these tones.

- 1 Press and hold the  (Menu) button for 3 seconds during a communication session.

The DTMF soft keyboard appears on the display.

### Note

When “Display DTMF button” is set to “On” on Page 10/11 of the Administrator Setup menu, the  (DTMF button) appears on the right side of the communication screen. You can also display the DTMF soft keyboard by clicking the  (DTMF button).

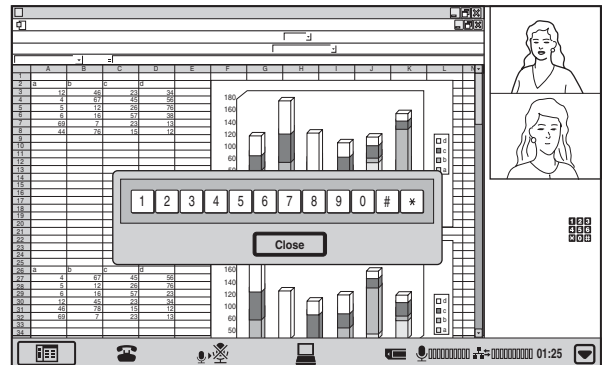

- 2 Click the numbers buttons that you want to send (0-9,#,\*).

When you click a button, the corresponding tone signal is transmitted to the remote party.

- 3 To stop transmitting tone signals, click “Close”.

The DTMF soft keyboard disappears.

---

# Accessing the Video Communication System

The following controls are available to access the Video Communication System. For details on each control, consult your Sony dealer.

---

## Using the Web Monitor Function

Images from the unit can be monitored from a Web browser.

To enable monitoring of the unit's images, set "Web Monitor" to "On" in the Administrator Setup menu (page 32).

*For details on access and passwords, see "Administrator Setup Menu" on page 32.*

---

## Using a Web Browser

Accessing the IP address of the Video Communication System from a Web browser allows you to control or set up the System.

To permit accessing the Terminal, set "Web Access" to "On" in the Administrator Setup menu (page 32).

*For details on the password to access or Web control feature, see "Administrator Setup Menu" on page 32.*

---

## Using Telnet

Accessing the IP address of the Video Communication System from Telnet allows you to control or set up the System.

To permit accessing the Terminal, set "Web Access" to "On" in the Administrator Setup menu (page 32).

*For details on the password to access or Web control feature, see "Administrator Setup Menu" on page 32.*

# Data Conference Using Data Solution Module

## Chapter

# 5

This chapter shows you how to use the optional PCSA-DSM1 Data Solution Module to incorporate the screen display data of a computer or similar into a videoconference.

The optional PCSA-DSM1 Data Solution Module is designed for internal installation in the PCS-TL33. It allows sending the pictures or text data displayed on a computer connected to the PCS-TL33 to the remote party in a videoconference. You can also connect a projector to the Data Solution Module and display a high-resolution computer screen image sent by the remote party at the local site.

Even if no Data Solution Module is installed or if another videoconferencing system such as PCS-1/1P, PCS-11/11P, PCS-TL30, PCS-TL50, PCS-G50/G50P, PCS-G70/G70P, or PCS-1600 is used, the receiving party can view the computer images sent from the other party. However, the quality of the picture received will vary depending on the components of the system. If the Data Solution Module or Data Solution Box is installed, a higher frame rate (number of frames per second) is possible, which allows viewing high-resolution moving images from a computer. To display the computer images sent from the other party during PC mode, press the  (Videoconference) button on the system and switch to videoconference mode.

*For details on picture quality depending on the system configuration, see “Picture quality of the Data Solution Module” on page 75.*

*For details on RGB signal input/output specifications, see the section “Acceptable RGB Input/Output Signals” on page 117.*

### Note

If the position of the received computer image is off center, switch to PC mode and switch back to videoconference mode to correct the positioning.

### Restrictions on the IP address of the system when using the Data Solution Module

The IP address available for the PCS-TL33 Video Communication System is restricted when you use the PCSA-DSM1 Data Solution Module. Moreover, a network

for communication between the Data Solution Module and the PCS-TL33 should be set up to be a separate segment. As a result, unusable IP address is the value obtained from the AND operation with the address of the Data Solution Module for communication and the network mask.

(Unusable IP address for the PCS-TL33) = (IP address of the PCSA-DSM1) & (Network mask)

The IP address of the PCSA-DSM1 is fixed at “192.254.1.2”. If the Network mask is assumed to be “255.255.0.0”, an unusable IP address is as follows:

$$192.254.m.n \quad (0 \leq m \leq 255, 0 \leq n \leq 255)$$

### Note on the camera picture when using the Data Solution Module

When transmitting a signal via the Data Solution Module, the camera picture quality will be lower owing to the decreased number of frames.



# Installing the Data Solution Module

## Notes

- Be sure to turn the power to all components off before starting the installation.
- When the Data Solution Module has been connected and is used for the first time, the Video Communication System may automatically upgrade the software of the Data Solution Module. While the upgrading message is displayed, never turn off the Video Communication System, to prevent the possibility of serious system damage.

### 1 Remove the rear cover.

Pull the cover off towards you.

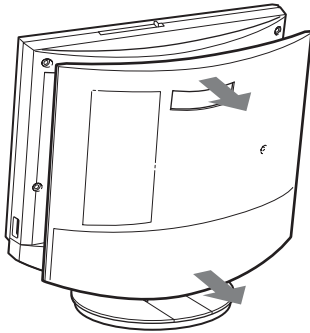

### 2 Remove the DSM connector cover.

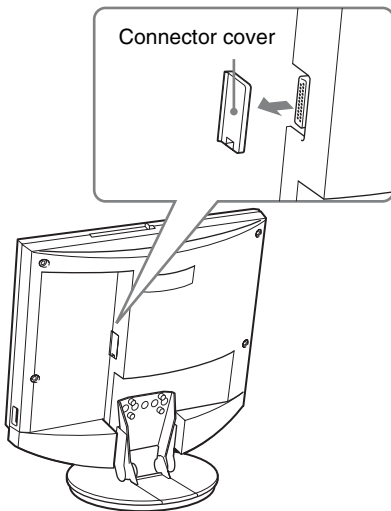

### 3 Connect the system connector of the Data Solution Module to the DSM connector of the PCS-TL33 and secure with fastening screws.

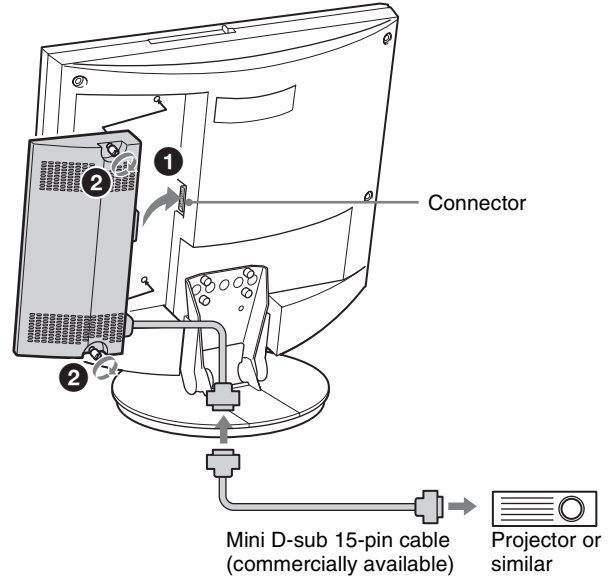

### 4 Replace the rear cover of the PCS-TL33.

Push the cover in while aligning the four stubs.

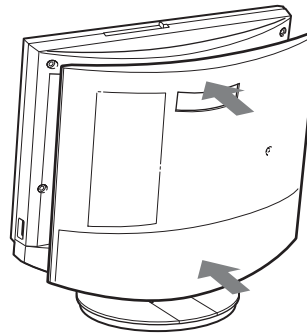



# Connection Example Using the Data Solution Module

## Notes

- Before making any connections, be sure to turn power to all components off.
- To prevent damage to the unit, do not connect or disconnect any cable while power to the unit is turned on.

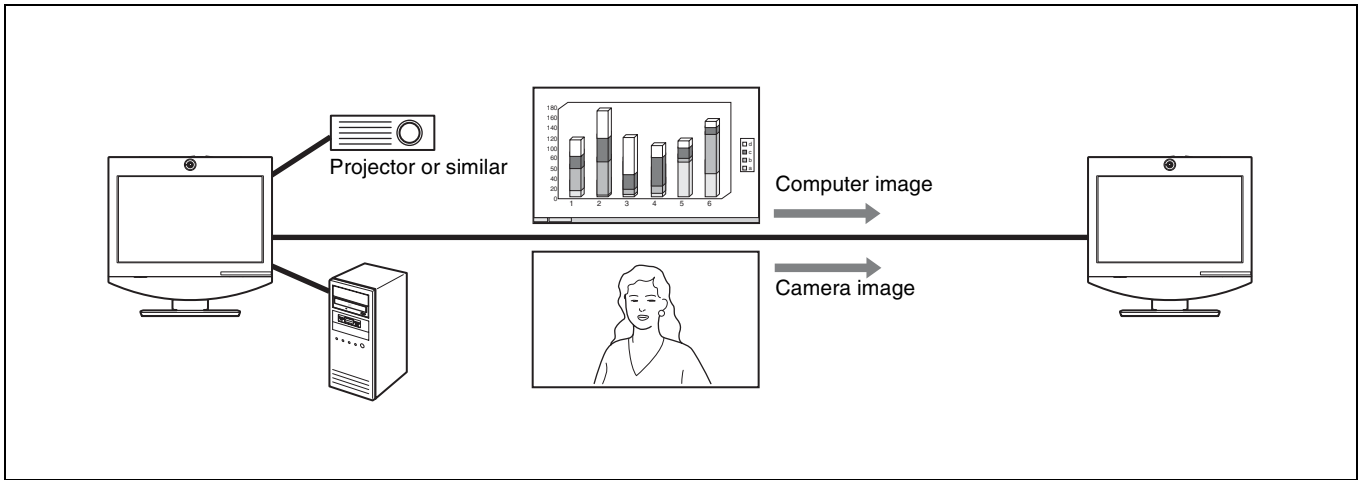

### Notes on the connection example

Connecting a projector or similar to the RGB OUT connector of the Data Solution Module enables the following features:

- Displaying the received computer picture with optimum picture quality
- Transmitting the picture of a locally connected computer to the remote party



## Using Video From Connected Equipment for a Conference

### Operating the System During a Conference

#### To transmit a picture from a computer

First, press the  (PC) button, and make sure that the computer images input are displayed and that the Data Solution Module supports the RGB IN signals. Be aware that although WXGA can be displayed on the screen, it cannot be sent.

*For details on acceptable RGB IN signals on the Data Solution Module, see “PCSA-DSM1 Data Solution Module (RGB IN) (Connector located on PCS-TL33)” on page 117.*

Next, press the  (Menu) or  (Videoconference) button to display the communication control bar, and click the  (Send) button.

The computer picture is displayed on a projector connected to the RGB OUT connector and on the Video Communication System, and it is also transmitted to the remote party.

To stop the transmission, click the same  (Stop) button.

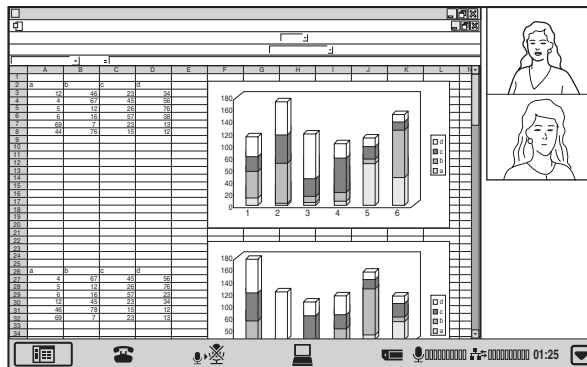

The computer picture displayed on a projector and on the Video Communication System is the image as input to the Data Solution Module. However, the image transmitted to the remote party may be lacking in detail and may have dropped frames.

*For details on picture quality, see “Picture quality of the Data Solution Module” on page 75.*

**Note**

While you are transmitting a computer picture, you cannot receive a still image or a computer picture from any other terminal. Ending your transmission enables you to receive it. While you are receiving a still image or computer picture from any other terminal, you cannot transmit a computer picture.

**Picture quality of the Data Solution Module**

The picture quality received by the remote party varies depending on the type of terminal and connecting method, and the “Monitor Out (or Sub Monitor Out)” settings at the remote site. Using a Data Solution Module also on the remote site enables reception of a high-quality computer picture with a higher frame rate.

**When the PCS-TL33 or PCS-TL30 is used as a receiving terminal**

Data Solution Module attached	Resolution	Video frame rate	Picture quality
No (Display on the PCS-TL33 or PCS-TL30)	◎	○	Outputs the signal by converting a transmitted VGA, SVGA or XGA signal into an XGA signal. The high-resolution picture can be obtained. The number of frames displayed per second depends on the interface transmission rate. For example, one frame per second is obtained.
Yes	◎	◎	Outputs the signal by converting a transmitted VGA, SVGA or XGA signal into an XGA signal. The high-resolution picture can be obtained. You can view a more vivid picture than the picture output from the display on the Video Communication System. The number of frames displayed per second depends on the interface transmission rates. For example, five frames per second are obtained at 1 Mbps. <b>Note</b> Three frames per second are obtained for a transmitted XGA signal.

◎: High, ○: Middle, △: Low

**When the PCS-TL50 is used as a receiving terminal**

Output connector for a computer picture on receiving terminal	Resolution	Video frame rate	Picture quality
Display on the PCS-TL50	◎	○	Outputs the signal by converting a transmitted VGA, SVGA or XGA signal into an XGA signal. The high-resolution picture can be obtained. The number of frames displayed per second depends on the interface transmission rate. For example, one frame per second is obtained.
RGB OUT on the PCSA-DSB1S (only when the PCSA-DSB1S is enabled)	◎	◎	Outputs the signal by converting a transmitted VGA, SVGA or XGA signal into an XGA signal. The high-resolution picture can be obtained. You can view more vivid picture than the picture output from the RGB OUT connector on the Video Communication System. The number of frames displayed per second depends on the interface transmission rates. For example, five frames per second are obtained at 1 Mbps. <b>Note</b> Three frames per second are obtained for a transmitted XGA signal.

◎: High, ○: Middle, △: Low

## When the PCS-1/1P, PCS-G70/G70P, or PCS-G50/G50P is used as a receiving terminal

Monitor used to display the picture of the Data solution Box	Output connector for a computer picture on receiving terminal	Resolution	Video frame rate	Picture quality
VIDEO OUT 1 or VIDEO OUT 2	VIDEO OUT 1 or VIDEO OUT 2 on the communication terminal	○	○	Outputs the signal by converting a transmitted VGA, SVGA or XGA signal into a 4CIF signal. The original high-resolution picture cannot be obtained and details cannot be clearly seen. The number of frames displayed per second depends on the interface transmission rate. For example, one frame per second is obtained at 1 Mbps.
RGB OUT	RGB OUT on the communication terminal	◎	○	Outputs the signal by converting a transmitted VGA, SVGA or XGA signal into an XGA signal. The high-resolution picture can be obtained. The number of frames displayed per second depends on the interface transmission rate. For example, one frame per second is obtained at 1 Mbps.
DSB	RGB OUT on the PCSA-DSB1S (only when the PCSA-DSB1S is enabled)	◎	◎	Outputs the signal by converting a transmitted VGA, SVGA or XGA signal into an XGA signal. The high-resolution picture can be obtained. You can view more vivid picture than the picture output from the RGB OUT connector on the Communication Terminal. The number of frames displayed per second depends on the interface transmission rates. For example, five frames per second is obtained at 1 Mbps (three frames per second with a XGA transmission).

◎: High, ○: Middle, △: Low

For the settings for output of the picture from each output connector, see the Operating Instructions supplied with the PCS-1/1P, PCS-G70/G70P, or PCS-G50/G50P.

## When the PCS-11/11P is used as a receiving terminal

Resolution	Video frame rate	Remarks
○	○	Outputs the signal by converting a transmitted VGA, SVGA or XGA signal into a 4CIF signal. The original high-resolution picture cannot be obtained and details cannot be clearly seen. The number of frames displayed per second depends on the interface transmission rate. For example, one frame per second is obtained at 1 Mbps.

◎: High, ○: Middle, △: Low

## When other videoconferencing system such as the PCS-1600 is used

Resolution	Video frame rate	Remarks
○	△	Sends and receives the pictures in 4CIF, and the original high-resolution picture cannot be obtained and detailed portion cannot be clearly seen. The number of frames displayed per second depends on the interface transmission rates. For example, one frame per several seconds is obtained.

◎: High, ○: Middle, △: Low

When confidentiality is required for a videoconference or a videoconference is held via the Internet, the Video Communication System enables transmission and reception of encrypted video, audio, and data. Conducting a videoconference using this feature is known as an encrypted videoconference via LAN.

This chapter describes how to conduct an encrypted videoconference via LAN.

The capability to conduct an encrypted videoconference via LAN is available only when using two PCS-TL33 units, or when the remote party uses a Sony Video Communication System PCS-1/1P, PCS-11/11P, PCS-TL30, PCS-TL50, PCS-G50/G50P, or PCS-G70/G70P, or when the remote party uses videoconferencing equipment from other manufacturers supporting H.235 encryption.

The encryption feature can also be used in multipoint videoconference using LAN connection (including cascade connection via LAN).

### Note

In an encrypted conference only video signals, audio signals, and computer picture data are encrypted. Camera control signals (for controlling the remote party's camera) will not be encrypted.

### Encryption protocol availability

Point-to-point videoconference

Encryption Protocol	Line I/F	LAN	SIP
Proprietary encryption		○	○
Standard encryption (H.233, H.234, H.235)		○	×

- : Encrypted videoconference available.
- × : Encrypted videoconference unavailable. The conference is conducted without encryption.

## Preparing for an Encrypted Videoconference via LAN

To start an encrypted videoconference via LAN, set “Encryption via LAN” to “On”, and select “Standard” or “Proprietary” under “Encryption Protocol” on Page 3/3 of the Communication Mode menu.

### Using standard encryption

- 1 Select “Standard” for “Encryption Protocol” under Page 3/3 of the Communication Mode menu.

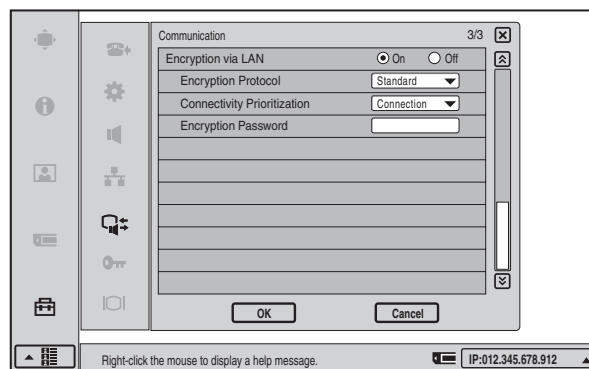

- 2 Select a “Connectivity Prioritization”.

### Connection priority

Connects with encryption to a remote party with standard encrypted connection enabled. Connects without encryption to parties unable to connect with standard encryption or parties with encryption set to off.

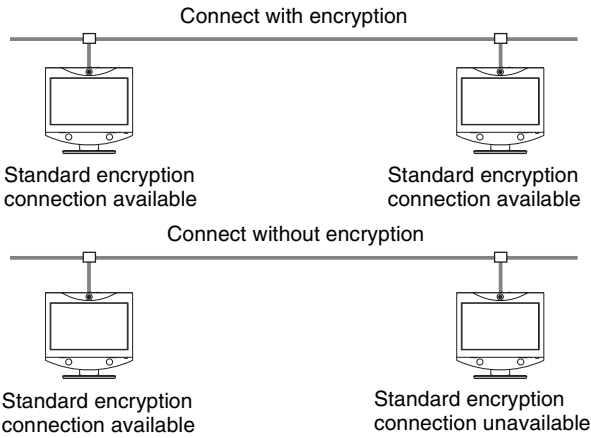

### Encryption priority

Connects only to remote parties with standard encrypted connection enabled.

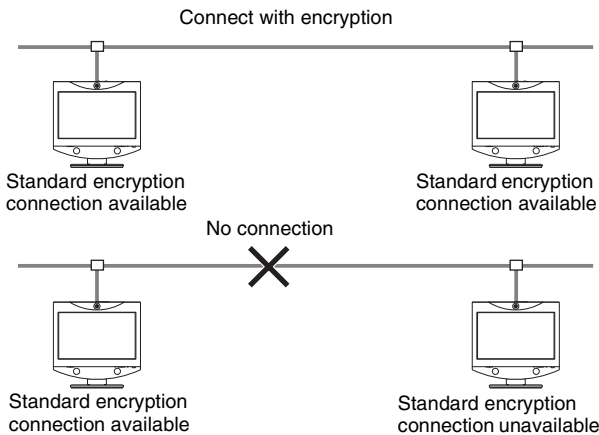

### Notes

- When the “Encryption Protocol” is set to “Standard”, no password is necessary.
- If you set “Encryption via LAN” to “On” with encryption given priority, you cannot connect to a terminal that is not equipped with the encryption feature, to a terminal with “Encryption via LAN” set to “Off”, or to a terminal without the same password as that of your system.

## Using proprietary encryption

- 1 Select “Proprietary” for “Encryption Protocol” under Page 3/3 of the Communication Mode menu.

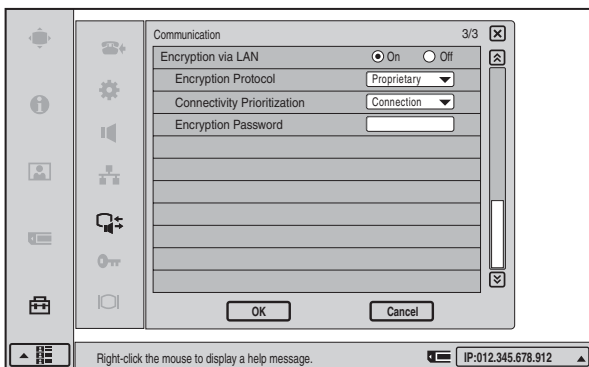





- 2 Enter the password (13 to 20 alphanumeric characters).

*For details on settings, see “Communication Mode Menu” on page 29.*

# Starting an Encrypted Videoconference via LAN

You can start an encrypted videoconference by calling a remote party in the same manner as a basic videoconference.

During an encrypted videoconference via LAN, either the  or  icon is displayed on the screen.

The  icon appears when “Proprietary” is set as the signal encryption protocol, and  appears when it is set to “Standard”.



## Note

When no icon is displayed on the screen, transmission and reception data will not be encrypted. Be sure to confirm that an icon is displayed before starting an encrypted videoconference.

## When the encrypted videoconference via LAN is disabled

If the following message appears when you call a remote party, an encrypted videoconference via LAN is not available.

Error Messages	Causes
The far-end system is not compatible with the encryption feature.	The encryption feature is not compatible with the remote system.
The encryption feature on a far-end system is disabled.	The encryption feature on a remote system is turned off, or the encryption protocol settings on the remote system are different from those on the local system.
The entered password for the encryption feature is not correct.	The password entered on the remote system is not the same as that on the local system.
The conference could not start because the encryption feature at the near-end side was disabled.	The encryption feature on the local system is turned off.

Error Messages	Causes
The conference could not start because the encryption feature at the far-end side was disabled.	The encryption feature on the remote system is turned off.
The conference could not start because the signal encryption method at the near-end side differed from that of the far-end side.	The encryption protocol settings on the remote system are different from those on the local system.
The standard encryption videoconference with SIP connection is not available.	You are connected to the remote system via SIP connection.
The remote party rejects answering.	The settings on the remote system are different from those on the local system.
The encryption feature on a far-end system is enabled.	The encryption feature on the local system is turned off.

This chapter describes how to conduct a videoconference using SIP (Session Initiation Protocol). SIP is a protocol to start communication via a network standardized by IETF (Internet Engineering Task Force).

For conducting a videoconference with an IP phone using SIP, installation of the optional PCSA-SP1 SIP software in this system and connection via a SIP server are required.

### **Restrictions on the use of the SIP software**

- The settings in the Setup menu are disabled during an SIP connection.
- An SIP connection cannot be established when “Encryption via LAN” is set to “On” and “Standard” is selected as the signal encryption method.



# Connection Examples for a Videoconference Using SIP

## Connection Example for Point-to-Point Videoconference

Connect the Video Communication System in which the optional PCSA-SP1 SIP software has been installed to an IP phone and a SIP server via a hub.

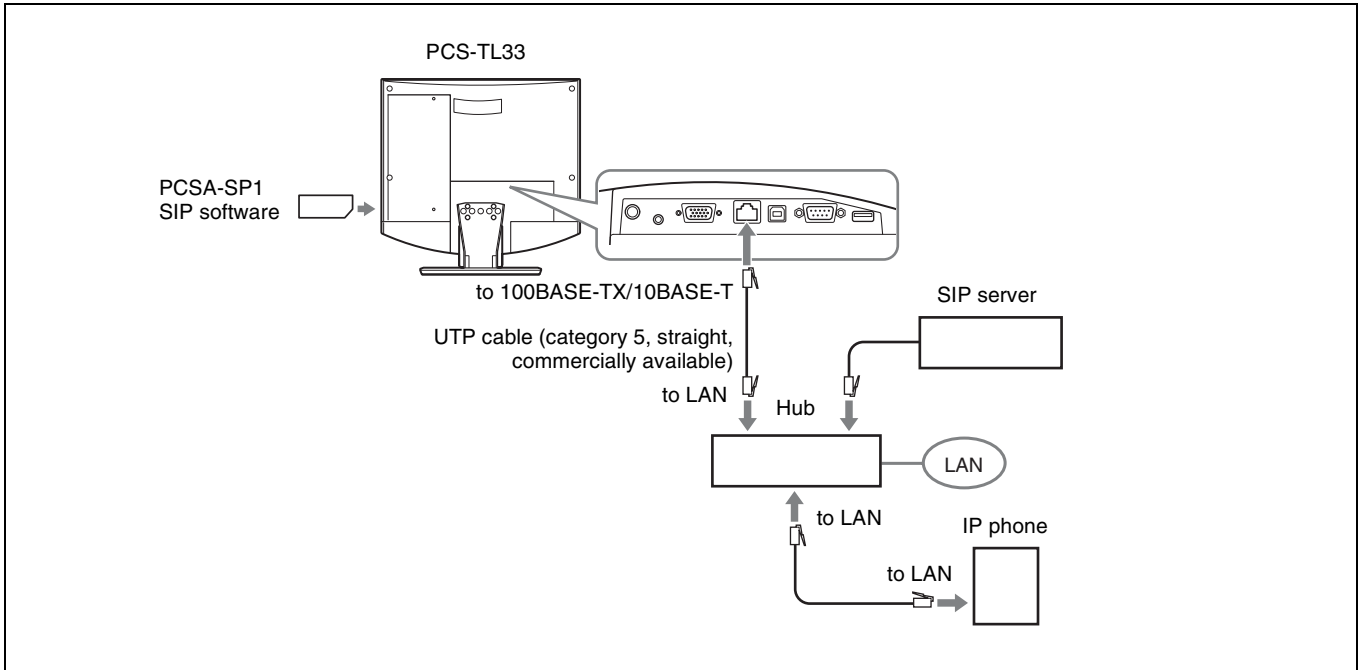

# Preparing for a Videoconference Using SIP

## Installing the SIP Software

### Notes on installing the SIP software

You cannot install the software if the write-protect tab on the “Memory Stick” in which the SIP software is stored is set to “LOCK”.

- Once the SIP software is installed in the Video Communication System, the software will not be used again.
- You cannot install SIP software which is copied to another “Memory Stick” with a computer, etc.

- 1 Turn the power off.
- 2 Insert the “Memory Stick” containing the PCSA-SP1 SIP software into the Memory Stick slot.

Insert the “Memory Stick” in the direction of the arrow on it.

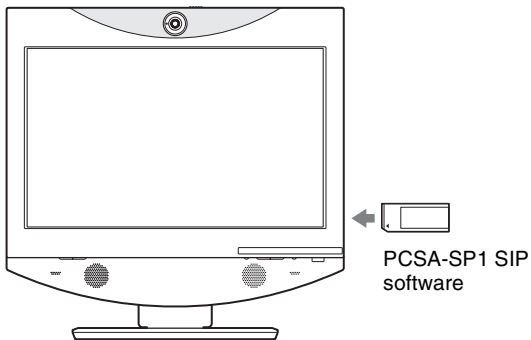

- 3 Turn the power on.  
The SIP software is installed in this system.

## Making Settings for SIP

You can set items regarding a videoconference using SIP under “SIP Setup” in the Network Setup menu.

- 1 On Page 1/3 of SIP on the Network Setup menu, set the “SIP Server Mode” item to “On”.

### Note

The “SIP Setup” item on the Network Setup menu appears only when SIP software has been correctly installed.

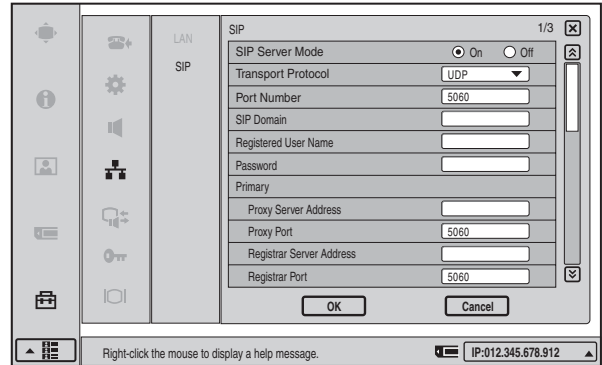

- 2 Enter the address and SIP domain name for the SIP server that is being used (proxy server or registrar server).

### Note

Make the settings for any other items as well, as required.

- 3 Enter the “Registered User Name” and “Password”.
- 4 Click “OK”.

The status of the synchronization with the SIP server is displayed.

**Registration Confirmed:** The synchronization with the SIP server is established.

**Registration Failed:** The synchronization with the SIP server failed.

*For details on how to make settings, see “Network Setup Menu” on page 27.*

## To select the Line I/F

You can set “SIP” as the default line interface selection for the launcher menu by setting “Line I/F” to “SIP” in the Dial settings of the Communication Mode menu.

*For details, see “Communication Mode Menu” on page 29.*

## Registering Remote Parties in the Phone Book

The basic procedure for registration is the same as the registration of a remote party for a point-to-point videoconference. For details, see “Registering a New Remote Party” on page 38.

# Starting a Videoconference Using SIP

## Calling Remote Parties

### To call a remote party using One Touch Dial

The basic procedure is the same as that for a normal point-to-point videoconference.

Move the mouse cursor to the desired remote party in the One Touch Dial list and click “Dial”.

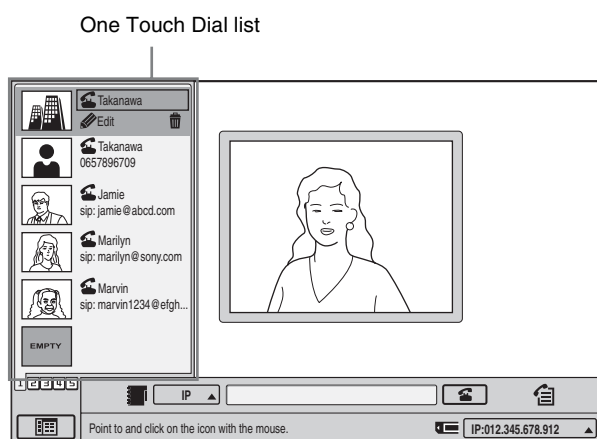

The system begins dialing the selected remote party and “Dialing” appears on the display.

When the connection to the remote party is established, the message “Communication starts!” appears on the display.

### To call a remote party registered in the Phone Book

The basic procedure is the same as that for a normal point-to-point videoconference.

In the Phone Book menu, move the mouse cursor to the desired remote party and click .

The system begins dialing the selected party and “Dialing” appears on the display. When the connection to the remote party is established, the message “Communication starts!” appears on the display.

*For details of the procedure, see “Calling a Remote Party Registered in the Phone Book” on page 53.*

### To call a remote party from the History menu

The basic procedure is the same as that for a normal point-to-point videoconference.

In the History menu, move the mouse cursor to the desired remote party and click “Dial”.

The system begins dialing the selected remote party and “Dialing” appears on the display. When the connection to the remote party is established, the message “Communication starts!” appears on the display.

*For details, see “Calling a Remote Party From the Incoming/Outgoing Call History” on page 54.*

### To call a remote party not registered in the Phone Book

The basic procedure is the same as that for a normal point-to-point videoconference.

Select “SIP” for the line interface, enter the address of the remote party in the number entry text box, and click “Dial.”

#### Note

Make sure “SIP Server Mode” is set to “On” in SIP setup.

Possible address formats for connection via SIP are as follows:

- 4000 (number assigned by the SIP server)
- 4000@sip.com
- 192.168.1.1 (IP address)

#### Note

When dialing an IP address, you must set “SIP Server Mode” to “Off” under SIP of the Network Setup menu.

The system begins dialing the selected party and the indication “Dialing” appears on the display. When the connection to the remote party is established, the message “Communication starts!” appears on the display.

*For details of the procedure, see “Calling a Remote Party by Entering the IP Address in the Launcher Menu” on page 53.*

## Receiving a Call From a Remote Party

Operations are the same as those for a point-to-point videoconference.

For details, see “Receiving a Call From a Remote Party” on page 55.

---

## Putting a Videoconference on Hold

- 1 Click the  (Disconnect) button.

A message appears on the screen.

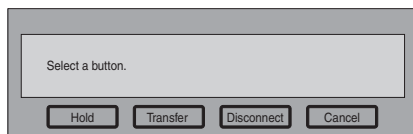

- 2 Click “Hold”.

The message “The call is on hold.” appears on the screen, and the videoconference enters a hold state. While the videoconference is on hold, the hold sound continues to play. To disable the hold sound, set “Sound Effect” in the Audio Setup menu to “Off”.

For details on the Audio Setup menu, see “Audio Setup Menu” on page 27.

### To cancel a hold

Click “Resume”.

#### Note

A hold state started by the remote party cannot be cancelled from the local site.

---

## Transferring a Videoconference

- 1 Click the  (Disconnect) button.

A message appears on the screen.



- 2 Click “Transfer”.
- 3 Dial the remote party you wish to transfer to, and click “Disconnect”.

You can dial from One Touch Dial, the Phone Book, or the History, or you can enter a number in the text box.

When transfer is complete, the message “Current call has been transferred.” appears on the screen.

### To cancel a transfer

When cancelling before dialing, click “Cancel” on the bottom right of the screen.

When cancelling after dialing, click “Disconnect”.

---

## Ending a Videoconference

Click the  (Disconnect) button, obey the message that appears, and click “Disconnect”.

When you are not conducting a videoconference, you can use the display of the Video Communication System as a computer display.

This chapter describes the use of the Video Communication System other than as a videoconference terminal.

---

## Using as Computer Display

By connecting the Video Communication System to a computer, you can view the picture from a computer on the display of the system.

---

### Connecting to a Computer

Remove the rear cover of the Video Communication System and connect a computer.

*For removing the rear cover, see page 15.*

When a computer is connected, you can either use a separate mouse for the PCS-TL33 and the computer, or you can link the PCS-TL33 and the computer using a USB cable (commercially available) and control both devices with the same mouse.

#### Note

Use a USB cable that is 3 m (10 ft.) or shorter.

## Separate Mouse

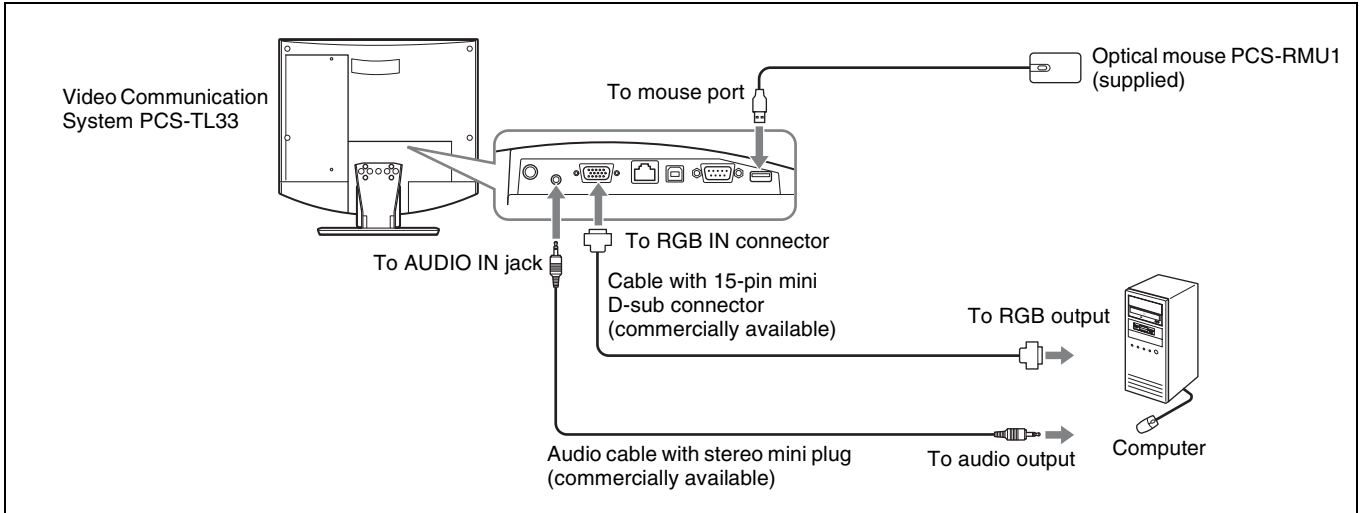

## Shared Mouse

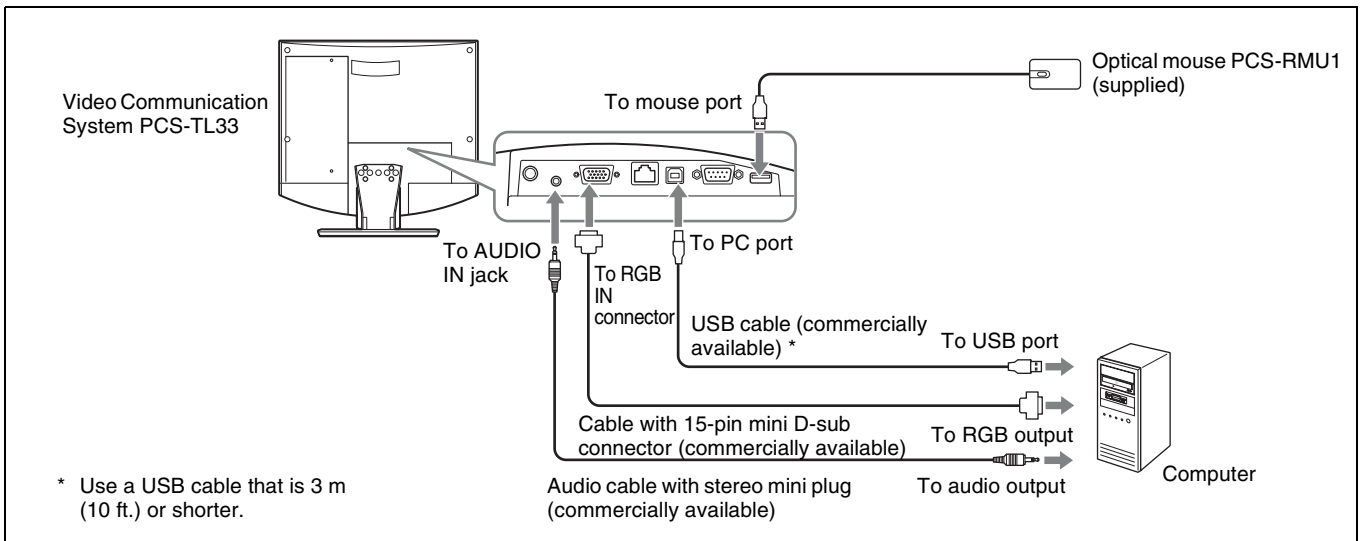

---

## Displaying the Picture From the Computer

- 1 Press the  (PC) button on the PCS-TL33.

The display is switched to the computer screen. When PC display is selected, the speakers of the PCS-TL33 reproduce the sound from the computer in stereo (if an audio connection has been established).

- 2 Use the  (Volume) buttons on the PCS-TL33 to adjust the volume of the computer sound.

- 3 Adjust the image quality.

*For details on the adjustment, see “Display Setup Menu” on page 36.*

---



## Displaying the Picture From the Computer During a Videoconference

To view the picture from the computer during communication, press the  (PC) button on the PCS-TL33. The system automatically enters Picture-in-Picture mode, and the video from the remote party is displayed as a window picture.

To change the screen layout, press the  (Menu) button on the PCS-TL33 and bring up the setup menu bar.

*For details on selecting the display mode, see “Switching the Display” on page 61.*

# Switching Between Videoconference Display and Computer Display

You can use the  (Menu) button,  (PC) button, and  (Videoconference) button at the bottom right of the unit to switch between the videoconference screen and computer screen display.

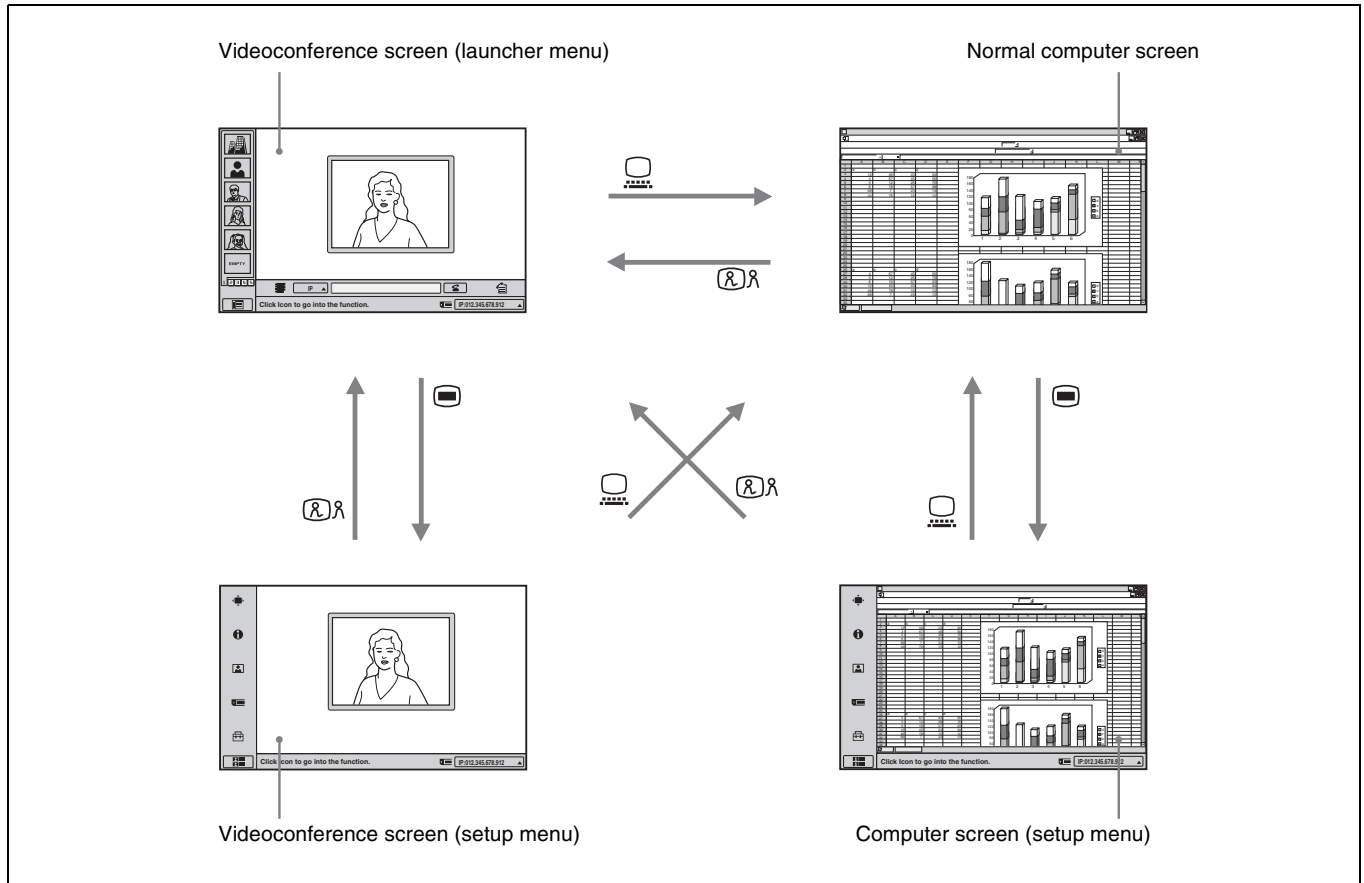

## Notes

- When the PCS-TL33 is not connected to a computer, pressing the  (PC) button to switch to computer display will disable the mouse.
- If a sub-picture is being displayed during a communication session, the sub-picture will remain visible also when you switch to computer display. However, the video shown on the sub-picture will be either from the remote system or the local system.
- When separate mice are being used for the PCS-TL33 and for the computer, the currently active mouse will depend on the current display screen. While the normal computer screen is displayed, the mouse connected to the computer is active. When other screens are displayed, the mouse connected to the PCS-TL33 is active.



# Calling a Remote Party or Receiving a Call at the PC Screen

## Calling a Remote Party While PC Screen Is Shown

While a computer image is shown on the display of the PCS-TL33, calling a remote party is not possible. You must first switch to the videoconference screen by pressing the **Ⓜ** (Videoconference) button on the unit.

*For details on calling a remote party, see “Starting a Conference by Calling a Remote Party” on page 48.*

## Receiving a Call While PC Screen Is Shown

When a call from a remote party is received, the procedure differs depending on whether Auto Answer or Manual Answer has been selected.

### Auto Answer mode

The system automatically receives the call from the remote party and the videoconference begins. However, screen display settings cannot be changed at the PC screen. Press the **Ⓜ** (Videoconference) or **Ⓜ** (Menu) button on the unit to switch to the videoconference screen.

### Manual mode

When there is an incoming call, a ringer tone sounds. You need to connect the call manually to start the conference, but this procedure is not possible at the PC screen. To begin a conference, obey the message on the screen, press the **Ⓜ** (Videoconference) button on the main unit, and click “OK”. The display switches to the videoconference screen.

You can also press the **Ⓜ** (Menu) button on the main unit and click “OK” to begin a conference.

### Note

When “Videoconference Button Answer” is set to “On” in the Answer Setup menu and you receive a call, you can start the conference by pressing the **Ⓜ** (Videoconference) button on the unit or reject the call by pressing the **Ⓜ** (PC) button.

# Adjusting the Picture Quality on the Display

You can adjust the picture quality on the display in the Display Setup menu.

The picture quality setting items differ depending on the picture (main picture) currently on the display: videoconference or picture from a computer. The adjusted values are retained for each of the two picture types, respectively.

- 1 Press “Display” in the screen to select the menu.

The Display Setup menu appears.

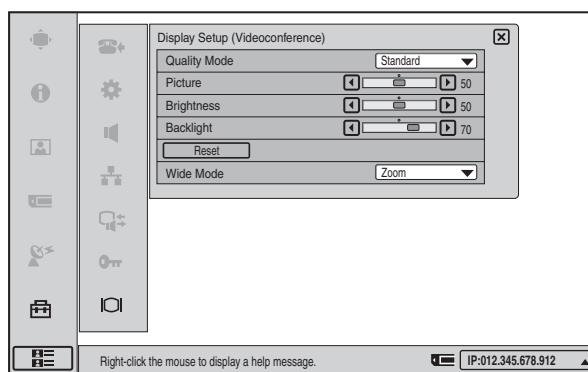

- 2 Make settings for the respective items, and then click **Ⓜ**.

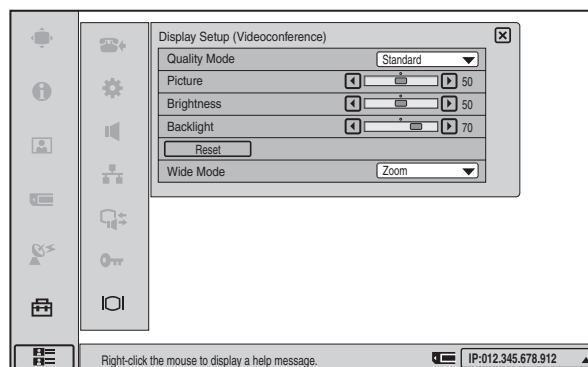

## Display Setup Menu for Videoconference



Setting item	Press ◀ to	Press ▶ to	Adjustment range
Quality Mode	select "Vivid", "Standard" or "Pro" from the pull-down list. "Vivid" for bluish tone, or "Pro" for reddish tone. The "Standard" setting is between "Vivid" and "Pro".		-
Picture	decrease picture contrast	increase picture contrast	0 to 100
Brightness	darken the picture	brighten the picture	0 to 100
Backlight	darken the backlight	brighten the backlight	0 to 100
Reset	Return Picture, Brightness, and Backlight settings to default values.		-
Wide Mode*	Normal: The 4:3 picture is displayed as it is.		-
	Wide: The wide picture is created by increasing the width of the 4:3 picture.		-
	Zoom: The wide picture is created by enlarging the 4:3 picture and cutting the upper and lower parts.		-

\* When Picture-and-Picture or Side-by-Side is selected for the screen layout, the display does not change.

## Display Setup Menu for the Computer Picture

The Display Setup menu for the computer picture consists of two pages. To switch between tabs, click  (return to previous page) or  (go to next page) at the right side of the screen.

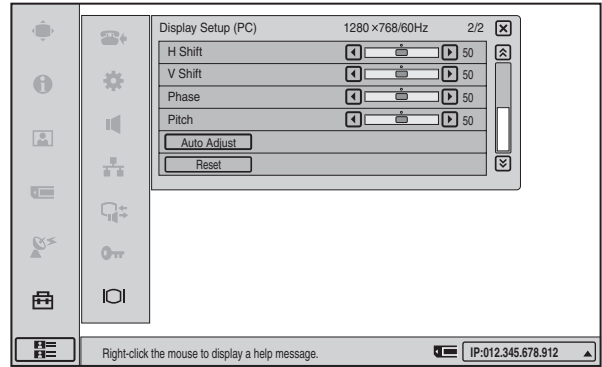
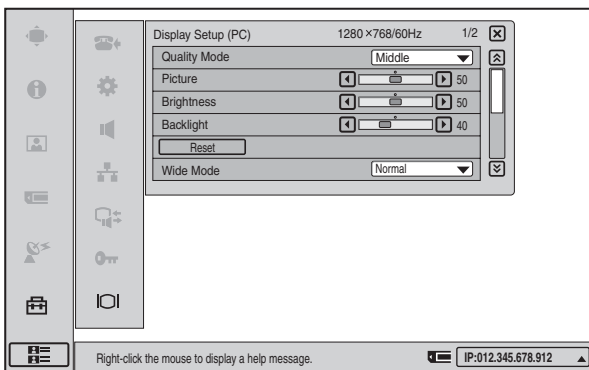

Page	Setting item	Press ◀ to	Press ▶ to	Adjustment range
1/2	Quality Mode	select the color temperature of the display from the pull-down list, "High", "Middle" or "Low".		-
	Picture	decrease picture contrast	increase picture contrast	0 to 100
	Brightness	darken the picture	brighten the picture	0 to 100
	Backlight	darken the backlight	brighten the backlight	0 to 100
	Reset	Return Picture, Brightness, and Backlight settings to default values.		-
	Wide Mode*	Normal: The 4:3 picture is displayed as it is.		-
Wide: The wide picture is created by increasing the width of the 4:3 picture.		-		
Zoom: The wide picture is created by enlarging the 4:3 picture and cutting the upper and lower parts.		-		
2/2	H Shift	shift the picture to the left	shift the picture to the right	0 to 100**
	V Shift	shift the picture downward	shift the picture upward	0 to 100**
	Phase	reduce blur of horizontal stripes and characters		0 to 63
	Pitch	eliminate vertical thick stripes		0 to 100
	AutoAdjust	adjust the phase and pitch automatically		-
	Reset	Return H Shift, V Shift, Phase, and Pitch settings to default values.		-

\* When Picture-and-Picture or Side-by-Side is selected for the screen layout, the display does not change.

\*\*The adjustment range for H Shift and V Shift may differ depending on the specifications of the input RGB signal.

## Differences in Wide Mode Settings

The “Wide Mode” item in the Display Setup menu changes the display as follows.

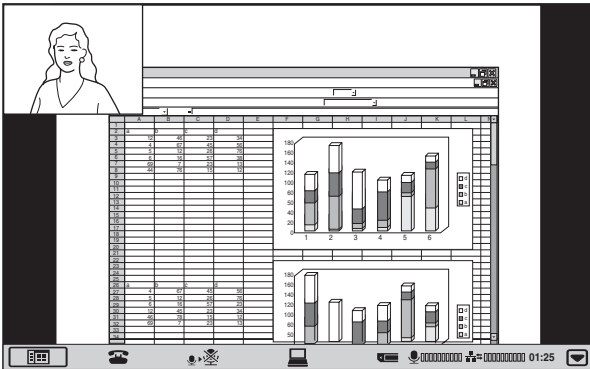

Normal

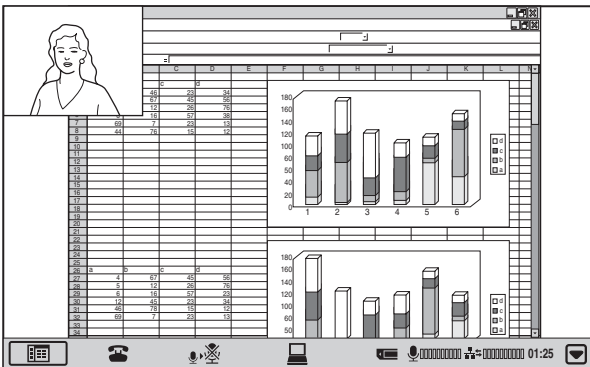

Zoom

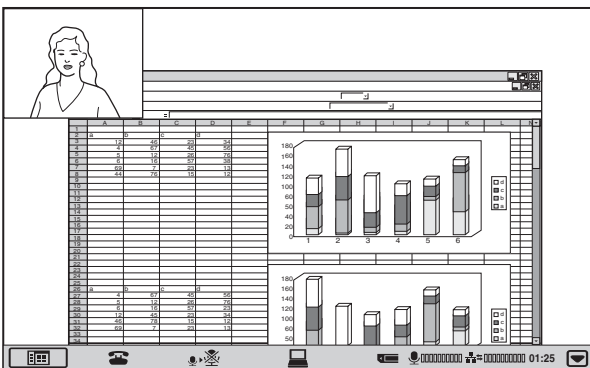



Wide

### To reset to the default picture quality

Click “Reset” button in the Display Setup menu.

#### Notes

- The setting items are different in videoconference mode and PC (computer display) mode.
- When the display screen is switched by pressing  (Videoconference) button or  (PC) button on the Video Communication System, the Display Setup menu disappears.

This chapter introduces the Web Control Function which is used to operate the PCS-TL33 over a LAN. The Web Control Function helps you control the PCS-TL33, or change its setup configuration, using a Web browser installed on your PC, such as Internet Explorer. The following is a set of Operating Instructions for the Web Control Function.

Internet Explorer is a product of the Microsoft Corporation. Please use Version 5.0, or above (Version 6.0 recommended).

---

## Open the Web Page

Enter the IP address assigned to the PCS-TL33 in the address line of your browser.

The format of an address is:

`http://XXX.XXX.XXX.XXX/`

For instance, if the IP address is “192.168.1.24”, enter “`http://192.168.1.24/`” in the address line.

### Notes

- When a proxy server in an external network segment has been set, the Gateway address in the PCS-TL33 LAN setting must also be set. Or set your Web browser proxy setting to “No Proxy” for the PCS-TL33.
- The window that appears after logging in uses your Web browser’s pop-up function. If you are using your browser’s pop-up blocker function, make sure to disable it.

## Identify a User

Once you reach the Web page, the following window will be displayed asking you to identify yourself as the user.



Enter one of the following user names (see below) into the “User Name” box and the corresponding password into the “Password” box, then click the [OK] button.

Each character of a password is shown as “\*” on the screen. When the user name and password are correct, the menu box will come up. If an incorrect user name or password is entered three times, an error message appears on the screen.

### Notes

- When you enter “user” in the “User Name” box and then its password (Remote Access Password) in the “Password” box, you can access and check the “Phone Book” and “Setup” pages.
- When you enter “super” in the “User Name” box and then its password (Phone Book Modification Password) in the “Password” box, you can access the “Phone Book” page, change the setting of the page, and register a new entry onto the page. And you can check the “Setup” page.
- When you enter “sonypcs” in the “User Name” box and then its password (Administrator Password) in the “Password” box, you can access the “Phone Book” page, change the setting of the page, and register a new entry onto the page. And you can check and modify the “Setup” page.
- If the corresponding password is not assigned, leave the “Password” box blank and click the [OK] button.
- Administrator Setup Password, Phone Book Modification Password and Remote Access Password settings are in the Administrator Setup menu.

## How To Use the “Web Control” Window

After logging in successfully, the “PCS-TL33 Web Control” window appears.



Clicking the [Mic Off], [Videoconference], [PC], and [Menu] buttons in the window have the same effect as pressing the respective buttons on the actual unit.

When you click the [Web Operation] button, the Dial/Disconnect page appears.

# Select a Tool

By clicking a tool button on the top part of the page, you can jump to the corresponding tool page. A brief introduction of each tool is presented below.

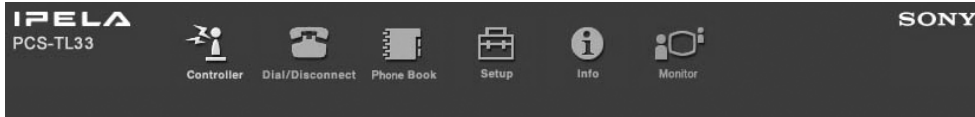

## [Controller]

Controls the PCS-TL33 using the on-screen controller.

## [Dial/Disconnect]

Calls a remote party, or ends a meeting.

## [Phone Book]

Displays the dial list.

Connects from the dial list.

Registers, confirms or edits the dial list.

For a private address book, the “Phone Book” button changes to the “Private Phone Book” button.



## [Setup]

Confirms or modifies the setup.

Sends messages.

Resets the setup functions (only when “sonypcs” has been entered as the user name).

## [Status & Info]

Displays the connection status, line status, or other machine information.

Displays the “Cause Code.”

Displays the “Call Log” (only when “sonypcs” has been entered as the user name).

## [Monitor]

Allows you to monitor images from the PCS-TL33.

### Note

When “Web Monitor” in the Administrator Setup menu is set to “Off”, you cannot monitor the images.

# How To Use “Controller”

To control the PCS-TL33 from the on-screen controller

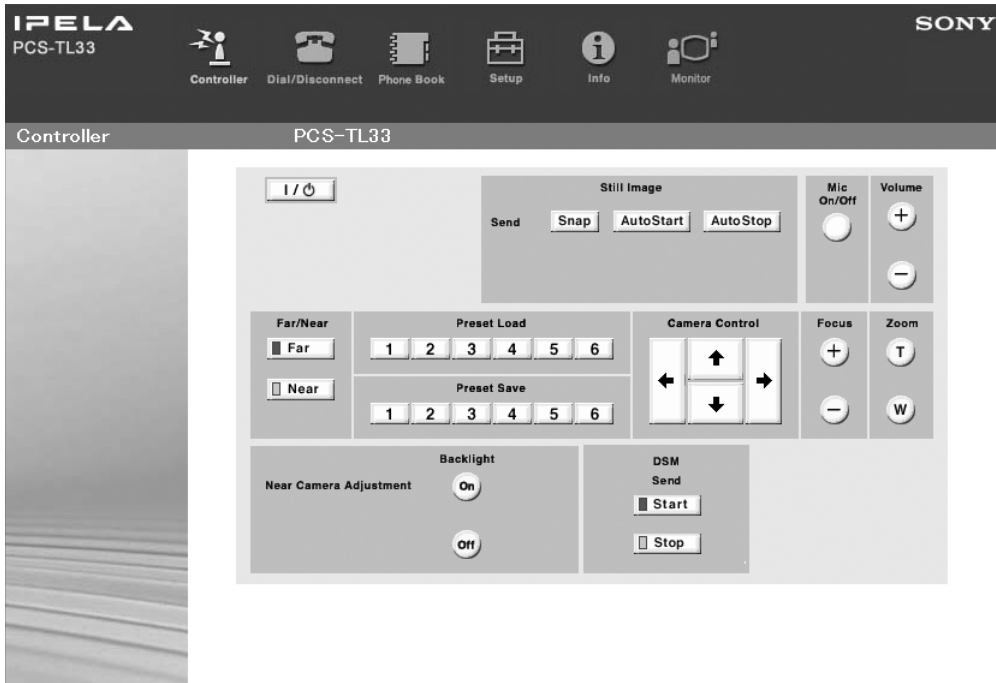

When you click the [Controller] button, the on-screen control panel appears. By clicking the buttons on this control panel, you can control the PCS-TL33, sending still images, operating the camera, registering preset camera settings, and so on.

For example, in order to preset and load a camera setting:

- 1 Set the camera at the desired position using the Camera Control buttons.
- 2 Click one of the “Preset Save” 1 to 6 buttons on the image.
- 3 The preset is done.
- 4 Click one of the “Preset Load” 1 to 6 buttons on the image to load it.

# How To Use “Dial/Disconnect”

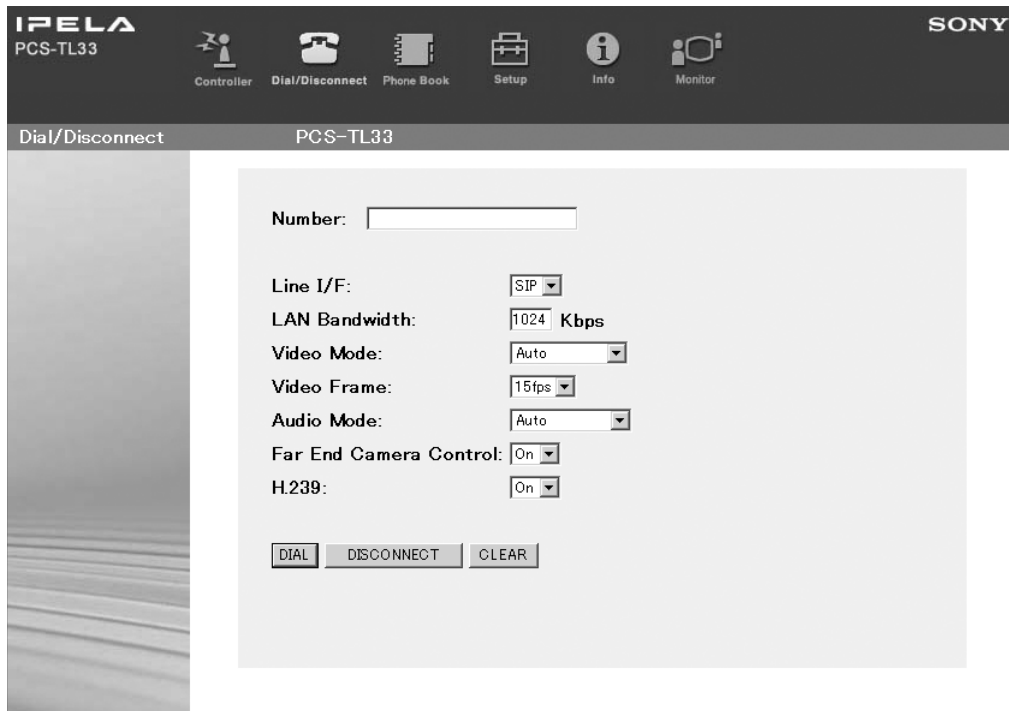

By clicking the [Dial/Disconnect] button, you can jump to the “Dial/Disconnect” page.

## To connect:

- 1 Enter the telephone number(s) of a remote party into the box(es): A1 (to C2) (When using a LAN, enter an IP address or a DNS name.)
- 2 Select the Line I/F, and configure any other necessary setting items.
- 3 Click the [DIAL] button.
- 4 The message, “Now dialing...” appears.
- 5 After the connection is made, the message, “Connect OK.” will appear, and the screen will return to the “Dial/Disconnect” page.

## To disconnect:

- 1 Click the [DISCONNECT] button.
- 2 The message, “Now disconnecting...” appears.
- 3 After the disconnection is completed, the message “Disconnect OK.” will appear, and the screen will return to the “Dial/Disconnect” page.

## To clear the dial number:

- 1 Click the [CLEAR] button.
- 2 The number(s) entered on this menu will be cleared and the screen will return to the “Dial/Disconnect” page.



# How To Use “Phone Book”

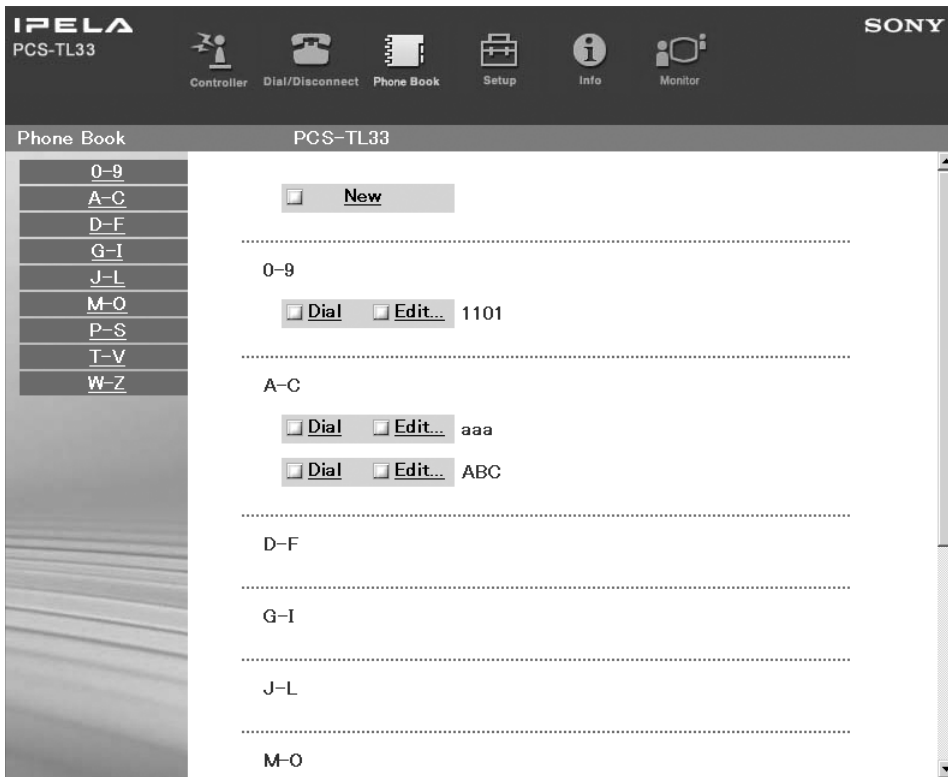

By clicking the [Phone Book] button, you can jump to the “Phone Book list” page.

## To connect:

- 1 Click  **Dial** next to the index title that you are dialing.  
Then, the message, “Now dialing...” will appear.
- 2 After the connection is made, you will see the message, “Connect OK.,” and the screen will return to the list page.

## “Phone Book-Edit” Page

The screenshot shows the 'Phone Book-Edit' page for device PCS-TL33. At the top, there is a navigation bar with icons for Controller, Dial/Disconnect, Phone Book, Setup, Info, and Monitor. Below this, the page title is 'Phone Book > Edit' and 'PCS-TL33'. On the left, there is a vertical menu with categories: 0-9, A-C, D-F, G-I, J-L, M-O, P-S, T-V, W-Z, and a 'Return' button. The main content area contains the following fields and options:

- Index:
- Number:
- Line I/F:
- LAN Bandwidth:  Kbps
- One Touch Dial:

At the bottom of the main content area, there are two buttons: [SAVE] and [DELETE].

To edit the communication attribute (only when “super” or “sonypcs” has been entered as the user name):

- 1 Click  **Edit...** next to the index title whose communication attribute you want to edit or modify on the list page.  
Then, the “Phone Book-Edit” page will appear.
- 2 Edit or modify the telephone numbers and attributes.
- 3 Click the [SAVE] button.  
After saving the changes, the screen will return to the list page.

To delete data from the Phone Book (only when “super” or “sonypcs” has been entered as the user name):

- 1 Click  **Edit...** next to the index title whose data you want to delete on the list page.  
Then, the “Phone Book-Edit” page will appear.
- 2 Click the [DELETE] button.  
After the deletion is complete, the list page will appear.

To return to the list page:

- 1 Click **Return** on the left part of the page.  
The list page will appear.

## “Phone Book-New” Page

The screenshot shows the 'Phone Book-New' page for the PCS-TL33 device. At the top, there is a navigation bar with icons for Controller, Dial/Disconnect, Phone Book, Setup, Info, and Monitor. Below this, the page title is 'Phone Book > New' and 'PCS-TL33'. On the left side, there is a vertical menu with the following options: 0-9, A-C, D-F, G-I, J-L, M-O, P-S, T-V, W-Z, and Return. The main content area contains the following fields and options:

- Index: [Text Input Box]
- Number: [Text Input Box]
- Line I/F: [Dropdown Menu] (Current selection: IP)
- LAN Bandwidth: [Text Input Box] (Current selection: 1024 Kbps)
- One Touch Dial: [Dropdown Menu] (Current selection: NONE)
- [SAVE] button

To register a new point (only when “super” or “sonypcs” has been entered as the user name):

- 1 Click  New on the list page.

The “Phone Book-New” page will appear.

- 2 Enter an index title into the Index box and telephone numbers into box(es) A1 (to C2).

- 3 Select the Line I/F, and configure any other necessary setting items.

- 4 Click the [SAVE] button.

After the registration is complete, the new index will be added, and the screen will return to the list page.

To return to the list page:

- 1 Click Return on the left part of the page.

The list page will appear.

# How To Use “Setup”

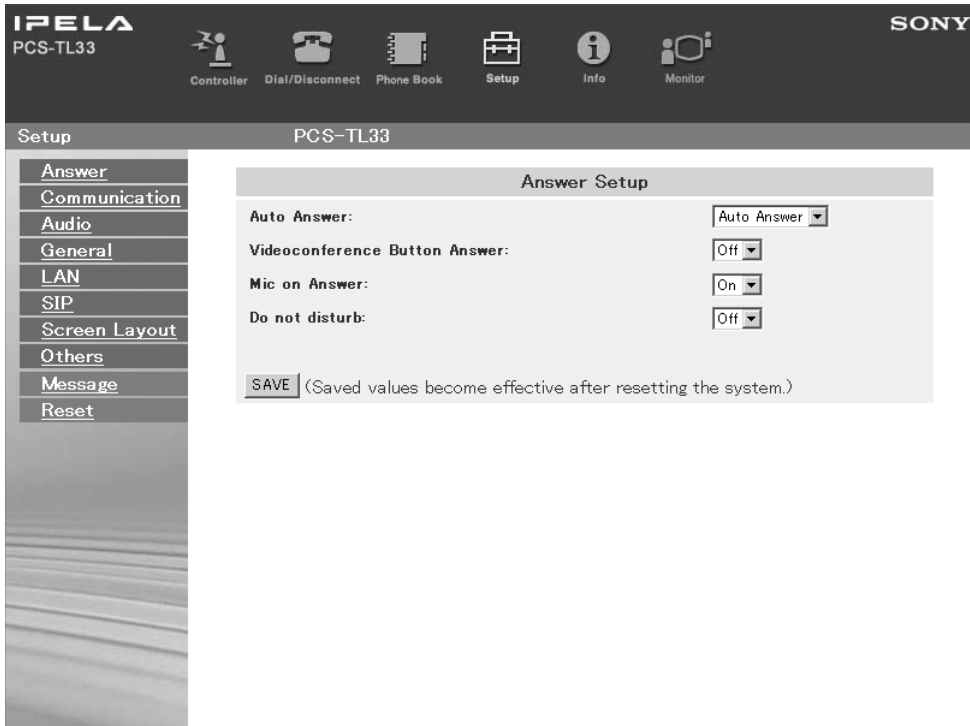

Click the [Setup] button, and you will jump to the “Answer” page.

Click [Answer](#), [Communication](#), [Audio](#), [General](#), [LAN](#), [SIP](#), [Screen Layout](#), [Others](#) on the left part of the screen, according to what you are setting up.

**To modify the attribute (only when “sonypcs” has been entered as the user name):**

**❶** Open the page whose attributes you want to modify.

**❷** Modify the attributes.

**❸** Click the [SAVE] button.

After the modification is complete, the screen will return to the same page as you see in step **❶**.

### Note

Sometimes the screen may not go back to the previous page after modifying the “LAN” page. This is not a malfunction.

# How To Configure KIOSK Mode

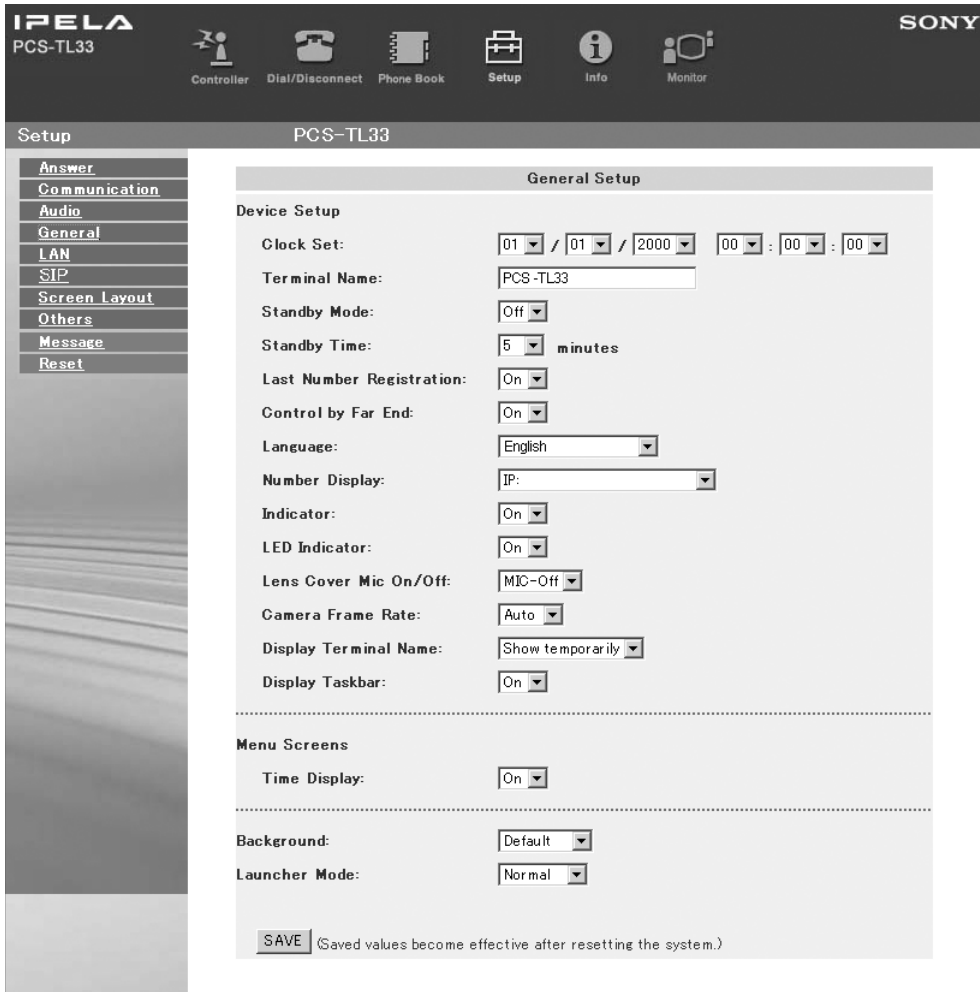

You can select the background of the launcher and select the launcher mode.

## Notes

- The KIOSK Mode setting can only be configured using the Web Control Function.
- For detailed information on the KIOSK Mode setting, consult your Sony dealer.

- 1 Click **General** on the left side of the page.  
The “General Setup” page will appear.  
(You can only configure this setting when “sonypcs” has been entered as the user name.)
- 2 Configure the “**Background**” and “**Launcher Mode**” settings.
- 3 Click the [SAVE] button.  
After saving, the screen will return to the “General Setup” page.

## To Display the “Send Message” Page

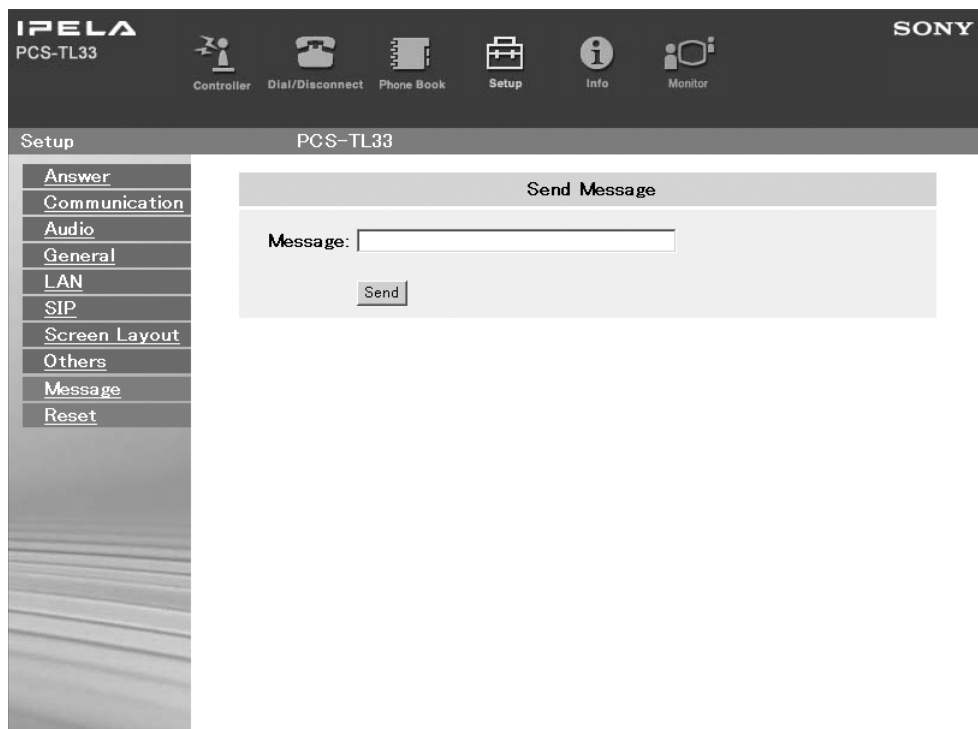

Click [Message](#) on the left side of the page.  
The “Send Message” page will appear.

Enter the message you want to send into the Message box  
and click the [Send] button to send the message to the  
PCS-TL33.

After the message is sent, “message send OK.” will be  
displayed and the screen will return to the “Send Message”  
page.

## To Reset the System

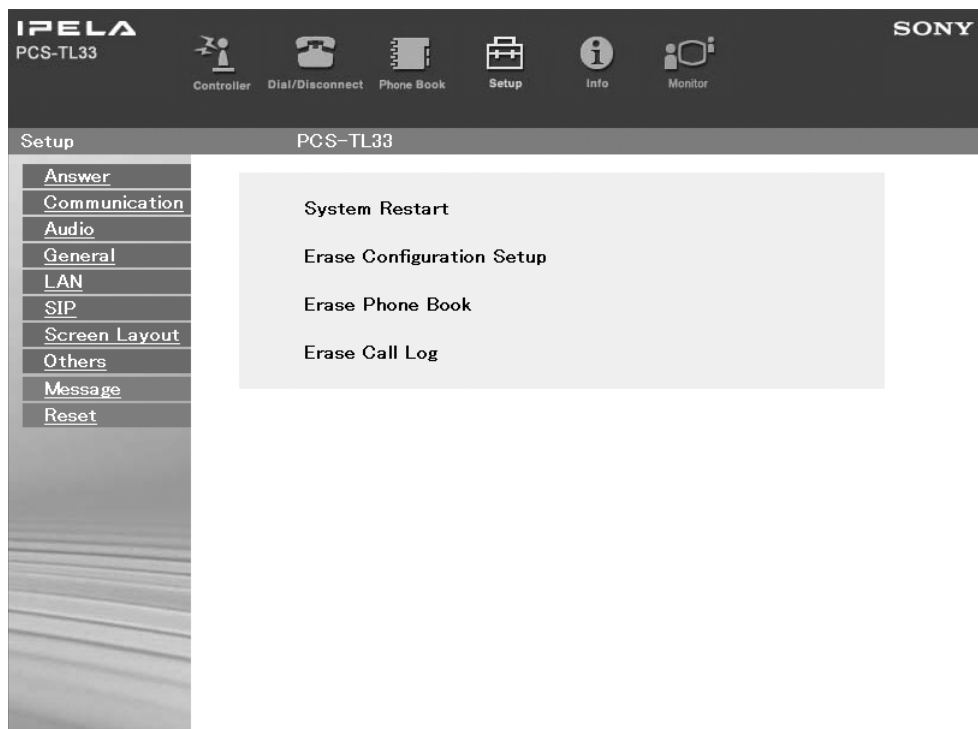

Click [Reset](#) on the left part of the page. The “Reset” page will appear (only when “sonypcs” has been entered as the user name).

**1 Click on the desired item.**

A dialog box will appear.

**2 Click the [OK] button.**

**“System Restart”**

Resets the PCS-TL33 system.

**“Erase Configuration Setup”**

Returns to the factory setting values.

**“Erase Phone Book”**

Erases all information saved in the “Phone Book.”

**“Erase Call Log”**

Erases all information saved in the “Call Log.”

# How To Use “Status & Info”

The screenshot shows the IP-ELA PCS-TL33 web interface. At the top, there are navigation icons for Controller, Dial/Disconnect, Phone Book, Setup, Info, and Monitor. The 'Info' icon is selected, leading to the 'Information' page for PCS-TL33. On the left, a sidebar menu includes Communication, Line, Machine, Cause, and Call Log. The main content area is divided into three sections: Line Status, Status, and Cause Code. Below these is a 'Machine Information' table.

Line Status	Status	Cause Code
LINE:	No call in progress	0
Machine Information		
Host Version:	Ver 0X.XX	
DSM Version:	Ver 0X.XX	
DSP Version:	Ver 0X.XX	
Software Option:	SIP	
Option I/F:	DSM	
HOST Name:		
IP Address:	XXX.XXX.XXX.XXX	
MAC Address:	XX-XX-XX-XX-XX-XX	
Serial Number:	XXXXXX	
LCD Version:	Ver 0X.XX	
Camera Version:	Ver 0X.XX	
AEC Version:	Ver 0X.XX	

Click the [Info] button, and the “Information” page will appear.

When the PCS-TL33 is on-line, the “Communication Status,” “Line Status,” and “Machine Information” page appears, and during otherwise, the “Line Status” and “Machine Information” page appears.



## To Display the Cause Code List

The screenshot shows the IP-ELA PCS-TL33 web interface. The top navigation bar includes icons for Controller, Dial/Disconnect, Phone Book, Setup, Info, and Monitor. The main content area is titled 'Information PCS-TL33'. On the left, a navigation menu has 'Cause' selected. The main area displays a list of Cause Codes with their corresponding descriptions.

Cause Code	Description
0	Unknown network error: Try again later.
1	Number does not exist: Check the number and try again.
2,3,6	Network congestion: Try again later.
16	Normal disconnection: (The line has been disconnected normally.)
17	Line is busy: Try again later.
18	System not responding: Check if the remote system is connected.
19	System not responding: Check if the remote system is connected.
21	Call rejected: Check if the remote system is connected.
22	Called party number changed: Check the number and try again.
26	Connection restoration request: Try again later.
27	Remote system out of order: Check if the remote system is operational.
28	Invalid number entered: Check the number and try again.
31,34,41,42,43,44,47	Network not available: Try again later.
50	Not a Subscriber: Check the remote party's facility contract.
57,58	Bearer capability not authorized: Check if the line rate is set correctly.
70	Restricted capability: Set the line rate to 56K and try again.
88	Terminal attribute error: Check the connection of the remote system.
91,95-102,111	Protocol error: Turn off and restart the system and try again.
128	H221 negotiation timeout: Turn off and restart the system and try again.
131	Board mismatch: Check the optional line interface boards.
132	Invalid SPID: Reregister the SPID.
134	Physical link synchronization error: Check the connection of the ISDN cable.
144,145	Bonding negotiation timeout: Turn off and restart the system and try again.
177	LAN connection timeout: Try again later.
178	LAN connection rejected: Try again later.
179	DNS error.
180	Dialing your own number is invalid.
181	GateKeeper error.

By clicking [Cause](#) on the left part of the page, you can jump to the “Cause Code” page, and see the Cause Code list.

## To Display the Call Log

The screenshot shows the IP-ELA PCS-TL33 web interface. The top navigation bar includes icons for Controller, Dial/Disconnect, Phone Book, Setup, Info, and Monitor. The main content area is titled 'Information PCS-TL33'. On the left, a navigation menu has 'Call Log' selected. The main area displays a table of call logs.

Start Date	Start Time	End Date	End Time	Duration	Index	Address	Launch	Type	Mode	Rate	Cause
01-11-2005	00:50:02	01-11-2005	03:58:58	000006:17:52		XX.XX.XX.XX	Dialout	LAN	P-P	1024K	0
01-10-2005	21:27:30	01-10-2005	23:58:50	000005:02:40		XX.XX.XX.XX	Dialout	LAN	P-P	1024K	0
01-06-2005	03:21:26	01-06-2005	03:23:52	000000:04:52		XX.XX.XX.XX	Dialout	LAN	P-P	1024K	0
01-06-2005	03:20:38	01-06-2005	03:20:38	000000:00:00		XX.XX.XX.XX	Dialout	LAN	P-P	0K	17
01-06-2005	03:07:12	01-06-2005	03:20:13	000000:26:00		XX.XX.XX.XX	Income	LAN	P-P	256K	0
01-01-2005	00:37:11	01-01-2005	00:42:10	000000:09:58		XX.XX.XX.XX	Dialout	LAN	P-P	1024K	0

By clicking [Call Log](#) on the left part of the page, you can jump to the “Call Log” page (only when “sonypcs” has been entered as the user name).

# How To Use “Monitor”

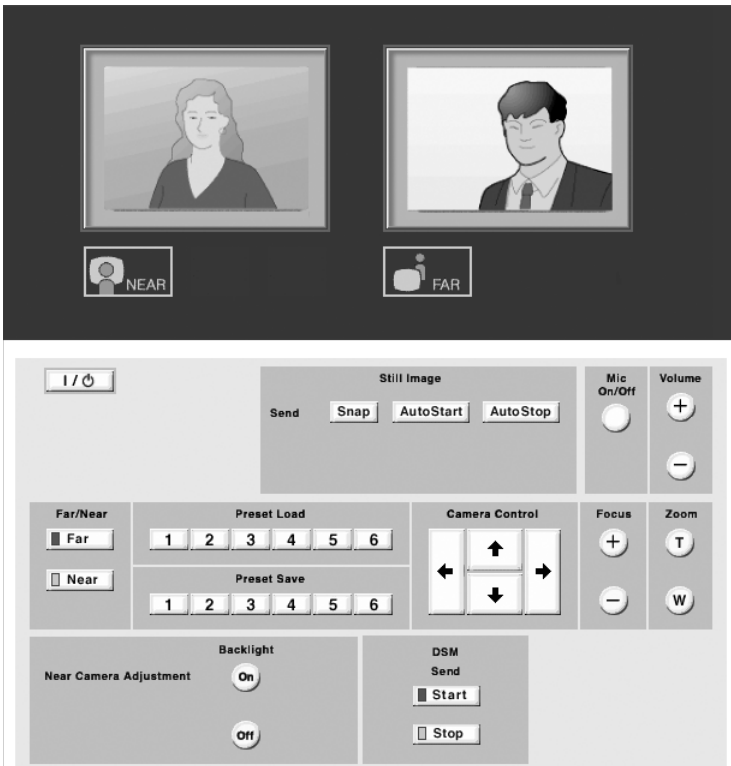

When you click the [Monitor] button, the “Monitor” page appears in a separate window allowing you to monitor images from the PCS-TL33.









## Note



When “Web Monitor” in the Administrator Setup menu is set to “Off”, you cannot monitor the images.

# Appendix

## Screen Indicators

The following indicators are displayed during videoconferences.

Indicator	Meaning
	Rejecting incoming calls.*
	Memory stick inserted in the memory stick slot.*
	Sending still images.
	Receiving still images.
	DSM data being sent or received.
	Receiving whiteboard images.
	Videoconference being held with standard encryption.
	Videoconference being held with proprietary encryption.

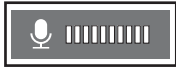
Indicator	Meaning
	Local video being broadcast.
	Videoconference being held with voice only.
	Shows the line status. When the indicator is displayed in red, the line is congested and picture or sound may be disrupted.
	Shows the microphone input level.

\* Also displays when communication is not in progress.

# On Screen Messages

Check the following if a message appears on the display when operating the Video Communication System.

Message	Meaning
Now obtaining an IP address via DHCP.	The IP address of your system is assigned automatically by the DHCP server. If the assignment is not successful, check the LAN settings.
Configure the DNS address or use the IP address to dial.	Enter a DNS address or enter the IP address of the remote party.
Access to the DNS server has failed. Check the PPPoE DNS settings.	Connection to the DNS server could not be established. Check the PPPoE DNS server settings.
Cannot access the DNS server. Use the IP address to dial.	Domain name connection could not be established. Enter the IP address of the remote party to connect.
Connection to the remote party via DNS disabled. Dial using IP address.	Domain name connection could not be established. Enter the IP address of the remote party to connect.
The LAN cannot be used.	You cannot use the LAN connection for some reason. Check for correct cable connections and verify that the LAN link LED indicators are lit. Also check the network settings.
Communication via LAN is not available. Check LAN connection.	Check for correct cable connections and verify that the LAN link LED indicators are lit.
LAN configuration error. Diffserve exceeds the maximum value.	Set the Diffserve item in the LAN Setup menu to a value between 0 and 64.
LAN configuration error. IP Precedence exceeds the maximum value.	Set the IP Precedence item in the LAN Setup menu to a value between 0 and 7.
LAN configuration error. NAT Mode is set to On. Check the NAT address.	LAN connection via NAT is enabled. Check the NAT address.
LAN configuration error. An address different from the NAT router is specified. Check the NAT address.	Enter the correct NAT address from the LAN Setup menu.
LAN configuration error. PPPoE is set to On. Check the PPPoE User Name and Password.	The LAN connection is set to use PPPoE. A user name and password must be set.
LAN configuration error. Fixed IP for PPPoE is set to ON. Check the PPPoE Fixed IP Address.	Connection is set to use a fixed IP address for PPPoE. Enter the correct fixed IP address for PPPoE.
LAN configuration error. (Gatekeeper error) Check LAN configuration.	Gatekeeper settings are not appropriate.
LAN configuration error. Gatekeeper Mode is set to On. Enter the gatekeeper address.	LAN connection via gatekeeper is enabled. Enter the gatekeeper address.
LAN configuration error. Unauthorized NAT address is specified. Check the NAT address.	The entered NAT address is not valid. Enter the correct NAT address.
LAN configuration error. Unauthorized network mask is set.	The subnet mask setting is invalid.
LAN configuration error. Connection is not complete as the port number overlaps.	Connection to the remote party could not be established. Check whether there is a conflict (overlap) between the "TCP port number" and "UDP port number" setting in the LAN Setup menu.
LAN configuration error. Connection is not complete as an invalid port number is specified.	Connection to the remote party could not be established. Check the "TCP port number" and "UDP port number" setting in the LAN Setup menu.
Upgrading the LCD driver software. Please wait.	The LCD software version is being upgraded. Do not turn power off until the upgrade process is completed.
PPPoE server admission fails. Dial again after confirmation of the PPPoE settings.	Connection to the PPPoE server could not be established. Check the various PPPoE settings and dial again.
Connection to the PPPoE server fails.	Check the DNS server settings.
The system is connecting to a LAN via PPPoE.	The system is connecting to a LAN via PPPoE.

Message	Meaning
PPPoE server authentication has failed.	Enter the correct password.
The standard encryption videoconference with SIP connection is not available.	When using an SIP connection, H.235 encryption is not available for encrypted videoconferences.
Connection using SIP is not available. 4xx response received.	Connection could not be established for example because the remote party uses media not supported by the PCS-TL33.
Connection using SIP is not available. 5xx response received.	Connection could not be established for example because of a SIP server error. Check the SIP server.
Connection using SIP is not available. 6xx response received.	Connection could not be established for example because the remote party could not be found. Check the number etc. of the remote party.
Connection using SIP is not available. Rejection received.	Connection could not be established because the remote party rejected the connection.
Connection using SIP is not available. Cancelled by the remote site.	Connection could not be established because the remote party cancelled the procedure.
Connection using SIP is not available. Disconnected by the remote site.	Connection could not be established because the remote party cancelled the procedure.
Connection using SIP is not available. Encrypted conference via LAN not available.	When LAN encryption is enabled, a SIP connection cannot be established.
Connection using SIP is not available. Maximum presences over.	Connection could not be established because the number of presences was exceeded.
Connection using SIP is not available. Provisional response timeout.	Connection could not be established because after sending there was no response from the remote party within the prescribed period.
Connection using SIP is not available. System call error.	Connection could not be established because of a system problem.
Connection using SIP is not available. Initialization error.	Connection could not be established because of an initialization problem.
Connection using SIP is not available. Unauthorized status.	Connection could not be established because of an undefined error.
Connection using SIP is not available. Server internal error.	Connection could not be established because of an internal error.
Connection using SIP is not available. Network error.	Connection could not be established because there is a network problem. Check the condition of the network.
Connection using SIP is not available. Line is busy.	Connection could not be established because the line of the remote party is busy.
Connection using SIP is not available. Parameter error.	Connection could not be established because of wrong settings. Check the settings on the SIP Setup menu etc.
Connection using SIP is not available. Unauthorized handle.	Connection could not be established because of an internal error.
Connection using SIP is not available. Undefined error.	Connection could not be established because of an undefined error.
Connection using SIP is not available. Memory over.	Connection could not be established because of insufficient memory in the PCS-TL33.
Connection using SIP is not available. Request timeout.	Connection could not be established because there was no response from the remote party within the prescribed period.
The remote party rejects answering.	Check the settings of the remote party.
The conference could not start because the signal encryption method at the near-end side differed from that of the far-end side.	Connection cannot be established if the local and remote parties use different encryption methods.
The encryption feature on a far-end system is disabled.	When attempting to start a videoconference using LAN encryption, it is not possible to connect if LAN encryption on the remote system is not turned on.
The conference could not start because the encryption feature at the far-end side was disabled.	Connection cannot be established if the encryption function on the remote site is off while the encryption function on the local site is on.
The encryption feature on a far-end system is enabled.	When attempting to start a normal videoconference without encryption, it is not possible to connect if LAN encryption on the remote system is turned on.
The far-end system is not compatible with the encryption feature.	When attempting to start a videoconference using LAN encryption, it is not possible to connect if the remote system does not support LAN encryption.

Message	Meaning
The remote terminal may not be registered in gatekeeper. Contact the gatekeeper administrator.	Contact the gatekeeper administrator regarding registration of the remote party terminal.
Call not responded.	Check connections of videoconferencing equipment at the remote party.
The entered password for the encryption feature is not correct.	Enter the correct password.
At least thirteen characters are required as a password for the encryption feature.	The password required for conducting videoconference using LAN encryption must be between 13 and 20 characters long.
Temperature is abnormal. The power will turn off.	The system is shutting down because abnormal temperature was detected.
Check the line interface or the IP address is set correctly.	Check whether the line type and IP address settings in the LAN Setup menu are correct.
No camera device is detected.	The camera could not be detected for some reason.
GateKeeper error.	Check the remote party address.
Gatekeeper does not respond.	Check the gatekeeper settings.
Gatekeeper does not respond.	User name and user number were entered, but the call could not proceed. Contact the gatekeeper administrator or enter the IP address of the remote party and retry the call.
Connection has been rejected as the data exceeds the bandwidth of a gatekeeper.	The connection requirements exceed the bandwidth limitations of the gatekeeper.
Gatekeeper registration error. Check LAN configuration.	Contact the gatekeeper administrator for information about gatekeeper registration for the remote party terminal.
The conference could not start because the encryption feature at the near-end side was disabled.	Connection cannot be established if the encryption function on the remote site is on while the encryption function on the local site is off.
RGB input signal not acceptable.	The RGB input signal in use is not compatible.
Communication ends.	Steps for ending a videoconference were completed successfully.
Communication starts!	Connection was established successfully and the videoconference can be started.
No more entries can be registered.	The maximum number of entries for the Phone Book has been reached.
The system will be reset.	The system is restarting.
The terminal with the specified IP address does not exist, or the system is turned off.	Connection to the remote party could not be established. Check whether the specified IP address is correct, or have the remote party turn the power on.
Please wait.	Data are being saved.
Dialing your own number is invalid.	Check the address for the remote party.
Now upgrading. Wait for a while. Be sure not to turn off your system while upgrading.	The software version of a camera device, LCD, or other equipment is being upgraded. Do not turn power off until the upgrade process is completed.
Still image saved to Memory Stick.	The still image was saved on the "Memory Stick".
The still image has been sent.	Still image data were sent.
Incorrect still image format. Progressive JPEG is not supported.	A JPEG file on the "Memory Stick" could not be decoded. The Progressive JPEG format is not supported.
A still image is being sent or received. The Data Solution Module (DSM) cannot be used.	Wait until still image transmission is completed before using the Data Solution Module (DSM).
Still image transmission cancelled.	The still image transmission was cancelled.
The still images were not sent.	The still image sending attempt failed.
The software upgrade is complete. The system will now restart.	The software upgrading process has completed normally.
Input title.	Enter an index title.
Network congestion: Try again later.	Available bandwidth is limited due to network congestion.
The network is heavily congested at the moment. Some pictures may appear distorted.	Data losses are occurring due to heavy network traffic. Video/audio quality may be impaired.
Adjusting the white balance. Please wait.	The white balance is being adjusted. When cancelled, the message will disappear, but the camera adjustment process is not cancelled.
The Data Solution Module (DSM) cannot be used.	The Data Solution Module cannot be used.
The power will turn off. Please wait.	The system is shutting down.

Message	Meaning
Name is not translated to IP address (DNS error). Check LAN configuration.	Check the DNS settings.
Reference to DNS has failed. Check LAN configuration.	When using a domain name server, the name for the remote party was entered, but LAN connection could not be established. Enter the IP address and dial again.
Now upgrading. Wait for a while.	The LCD software version is being upgraded. Do not turn power off until the upgrade process is completed.
Wrong password.	Enter the correct password.
Check the user name or user number for dialing is correct.	Enter the correct user name and user number.
Busy line - Connection not possible.	Cannot connect because remote party is busy.
File error.	There is a problem with the file.
File size error.	The file size allocation is wrong.
File decode error.	A JPEG file could not be decoded.
Format error.	The "Memory Stick" could not be formatted.
Unknown device is connected.	An unknown device has been connected to the mouse port.
Unknown network error: Try again later.	Try dialing once more.
Use of the Private Phone Book is available.	A "Memory Stick" containing Private Phone Book data was inserted. The Private Phone Book function can be used.
Use of the Private Phone Book is not available.	A "Memory Stick" containing Private Phone Book data was removed. The Private Phone Book function can no longer be used.
Preset 1 (- 6) selected.	Camera angle and zoom has been changed to the settings stored in preset number 1 (- 6).
Registered to Preset number 1 (- 6).	Camera angle and zoom settings have been stored in preset number 1 (- 6).
The presentation screen will not be sent.	The current presentation screen cannot be handled by the DSM. Set the PC screen resolution to XGA or lower.
White balance adjustment will be performed. Press the "Start" button and wait a few moments.	The white balance can be adjusted manually.
Microphone is turned off.	The microphone cannot be used.
Microphone is turned on.	The microphone can be used.
Mouse detected.	Mouse is connected to the Video Communication System.
No mouse is detected.	Mouse is not connected or connected to the PC side.
Memory Stick file decode error.	A JPEG file on the "Memory Stick" could not be decoded.
Memory Stick error.	The "Memory Stick" format is different.
Memory Stick file error.	The "Memory Stick" file format is different, or the file is damaged.
Memory Stick file size error.	The "Memory Stick" file size allocation is wrong.
No Memory Stick.	No "Memory Stick" is inserted.
Memory Stick write-protected.	Change the position of the LOCK slider on the rear of the "Memory Stick".
There are no images recorded in the Memory Stick.	No image files are stored on the Memory Stick.
Memory Stick full.	There is not enough free capacity on the "Memory Stick".
Memory full.	The "Flash Memory" does not have enough free space.
The cooling fan is malfunctioning.	There is a problem with the cooling fan.
Registration failed	The synchronization with the SIP server failed.
Registration Confirmed	The synchronization with the SIP server is established.
Router is not supported.	Make sure that you are using a router that is supported and that the router settings are correct.
Confirm the router's port settings.	Check the router settings.
Authentication error. Check that the password is correct.	Check the password.
Authentication error. Check that the ID is correct.	Check the ID.
The dialed party does not exist. Check that the number is correct.	Check the remote party's settings.
The call request has timed out.	Cannot connect due to a problem with the network or the remote party not answering within a specific time.

Message	Meaning
The remote party is unable to connect.	Check the remote party's settings.
Cannot connect because the line is busy.	Cannot connect because the remote party's line is busy.
The connection was canceled by the remote party.	Cannot connect because the remote party cancelled a call to the local site.
Connection failed.	Check the communication settings.
4xx response received.	Cannot connect due to reasons such as the remote party using media not supported by the unit.
5xx response received.	Cannot connect due to reasons such as a server error. Check the SIP server.
The connection was canceled by the remote party.	Cannot connect because the call was rejected by the remote party.
6xx response received.	Cannot connect due to reasons such as the remote party not being found. Confirm the remote party's number and settings.
Cannot connect using IPELA VC Link under the current settings.	Check the IPELA VC Link settings.
Cannot connect using SIP under the current settings.	Check the SIP settings.
Router is not supported. (No M-SEARCH response)	Make sure that you are using a router that is supported and that the router settings are correct.
Router is not supported. (Service unavailable)	Make sure that you are using a router that is supported and that the router settings are correct.
Router is not supported. (Failed to obtain WAN IP address)	Make sure that you are using a router that is supported and that the router settings are correct.
Router is not supported. (Port mapping failed)	Make sure that you are using a router that is supported and that the router settings are correct.
Cannot communicate through SIP. (Port mapping failed)	Make sure that you are using a router that is supported and that the router settings are correct.
There are no open ports. Confirm the router's port settings.	Make sure that you are using a router that is supported and that the router settings are correct.
Failing to automatically configure NAT settings.	Make sure that you are using a router that is supported and that the router settings are correct.
Cannot execute the Function Extension Command because the setting for use of the SIP server is enabled.	When using IPELA VC Link, make sure to disable the SIP server setting.
Rejected by server.	The call was disconnected by the remote party.
Authentication error.	Check the ID and password.
Cannot connect. Please try again later.	Try calling again later.
Router is not supported. (Port mapping delete failed)	Make sure that you are using a router that is supported and that the router settings are correct.
Unable to communicate. (Port mapping failed)	Make sure that you are using a router that is supported and that the router settings are correct.
Communication with UPnP is not available. (Timeout)	Make sure that you are using a router that is supported and that the router settings are correct.
Communication with UPnP is not available. (Busy)	Make sure that you are using a router that is supported and that the router settings are correct.
Communication with UPnP is not available. (Internal error)	Make sure that you are using a router that is supported and that the router settings are correct.
Connection with the selected line interface is not available in the current communication mode.	Check the current communication mode.
Disconnected because reception of packets from the far-end side has stopped.	Packets were not received properly.



# Troubleshooting

If the Video Communication System does not function correctly, check the following.

Symptom	Cause	Solution
The power is not turned on.	The power switch is not set to on.	Press the power switch on the right side (page 17).
The message "The cooling fan is malfunctioning."	The cooling fan built in the system has stopped.	Consult your Sony dealer.
No sound or the volume is very low.	The volume of the System is too low.	Adjust the sound volume by pressing the VOLUME + button on the PCS-TL33 (page 57).
	The microphone on the remote party is turned off.	Ask the remote party to turn on the microphone.
	The microphone or external equipment is not connected correctly.	Check the connection.
No picture.	The selected picture source is not tuned on.	Turn on the selected video equipment.
	The selected picture source is not correctly connected to the system.	Check the connections.
	A voice communication is held.	This is not a malfunction.
	Movement of the camera is prevented.	Turn off the Video Communication System, then turn it on again.
	The lens cover is closed.	Slide the lever for lens cover to the right to open the lens cover (page 17).
No connection.	Wrong number was dialed.	Check the entered number.
	The registered items in the Phone Book are not correct.	Register the party correctly referring to "Registering a Remote Party in the Phone Book" on page 38.

Symptom	Cause	Solution
No connection.	Some of the system settings are not correct.	Set the system settings correctly referring to "Registering Local Information" on page 24.
	The IP address and network mask are not set correctly.	Ask the system administrator to set them correctly (page 27).
	The LAN cable is disconnected.	Connect correctly (page 15).
	The LAN cable is connected to the incorrect connector.	Connect correctly (page 15).
	The LAN cable is down.	Replace the cable with a new one.
	The cable exclusively designed for the ISDN connection is used for LAN connection.	Use the cable for LAN connection.
	Incorrect type of cable (cross or straight cable) is used for the LAN connection.	Use the correct type of cable.
	If you repeat plugging/unplugging or turning on/off, you may not connect to the network for a while.	Turn off the power of the system and wait for a few minutes before turning it on again.
	LAN connection timeout.	Try again later.
	Packet for videoconferencing is not acceptable under the current LAN environment.	Consult with the system administrator so that the packet for videoconferencing becomes acceptable under your LAN environment.
	The remote terminal is not turned on.	Ask the remote party to turn on the terminal.
	It takes a long time for the remote party to be able to answer from the standby mode.	Ask the remote party to cancel the standby mode.
	The remote party is in communication with another party.	Call the remote party after they end the communication with another party.

Symptom	Cause	Solution
No connection.	Answering the call is not permitted by the remote terminal as it is operating for setups, etc.	Ask the remote party to permit answering a call.
	The remote terminal is not set to auto answer mode.	Ask the remote party to set the terminal to auto answer mode, or to answer a call manually.
	There is some problem with the remote terminal.	Try to dial the number of another terminal.
	A message appears on the screen.	See "On Screen Messages" on page 108.
Still pictures or the Phone Book cannot be saved to the "Memory Stick."	The write-protect tab on the "Memory Stick" is set to LOCK.	Release the lock (page 65).
	The "Memory Stick" has already been recorded to full capacity.	Use another "Memory Stick."

# Specifications

## PCS-TL33 Video Communication System

This unit is compliant with ITU-T Recommendations H.323 and IETF SIP.

### Motion picture

Operating bandwidth

64 kbps to 2048 kbps

Coding H.261/H.263/H.263+/H.263++/H.264 (ITU-T Recommendation)  
MPEG4 Simple Profile

Picture elements

CIF: 352 pixels × 288 lines

QCIF: 176 pixels × 144 lines

### Still Picture

Pixels 704 pixels × 576 lines

Encoding H.261 (ITU-T Recommendation) Annex. D (4CIF)

H.263 (special format of this system)

### Sound

Bandwidth 14 kHz (MPEG4 Audio)

7 kHz (G.722 compliant with ITU-T Recommendation)

3.4 kHz (G.711/G.728/G.729 compliant with ITU-T Recommendation)

Transmission rate

64 kbps, 96 kbps (MPEG4 Audio)

56 kbps, 64 kbps (G.711 compliant with ITU-T Recommendation)

48 kbps, 56 kbps, 64 kbps (G.722 compliant with ITU-T Recommendation)

16 kbps (G.728 compliant with ITU-T Recommendation)

8 kbps (G.729 compliant with ITU-T Recommendation)

### Network

Multiplexing Video, audio, data

Frame format H.225.0 (compliant with ITU-T Recommendation)

Interface LAN (100BASE-TX/10BASE-T)

LAN protocol supported

HTTP

FTP

Telnet

RTP/RTCP

TCP/UDP

SNMP

## Remote control

Far end camera control  
H.281 (compliant with ITU-T  
Recommendation)

## Camera

Image device 1/3.8 inch color CMOS  
Total pixel count: approx. 1.33 million  
Effective pixel count: approx. 1.28 million

Lens  $f = 2.1$  mm  
 $F = 1:2.4$   
Horizontal angle: approx.  $87^\circ$   
Vertical angle: approx.  $71^\circ$

Focal distance 300 mm

Pan/tilt/zoom function  
By digital processing

Auto White Balance function built-in

Auto Exposure function built-in

Frame rate Auto (switches automatically to match  
ambient illumination)/30/15 fps

## Display

Size 17.1 inch widescreen (Viewable area  
measured diagonally)

Resolution  $1280 \times 768$  (WXGA)

Maximum screen luminance  
 $410 \text{ cd/m}^2$

Response time 13 ms

Contrast ratio 600 : 1

Angle of view 176 degrees

Number of colors  
16,700,000 colors

## Display controller

PinP 4 corners

PandP Two/Three windows

Side-by-Side Two windows

Input Internal: Video Communication  
External RGB: Computer display

Wide mode Normal, Zoom, Wide

RGB mode  $640 \times 480$ ,  $800 \times 600$ ,  $1024 \times 768$ ,  
 $1280 \times 768$ , etc.  
Display of zoomed picture is possible.

## Speaker

Speaker 3 W  $\times$  2

## Microphone

Frequency range  
14 kHz

Directional characteristic  
Narrow-angle directional

## General

Power requirements  
19.5 V DC

Current consumption  
6.15 A

Operating temperature  
 $5^\circ\text{C}$  to  $35^\circ\text{C}$  ( $41^\circ\text{F}$  to  $94^\circ\text{F}$ )

Operating humidity  
20% to 80%

Storage temperature  
 $-20^\circ\text{C}$  to  $+60^\circ\text{C}$  ( $-4^\circ\text{F}$  to  $+140^\circ\text{F}$ )

Storage humidity  
20% to 80% (no condensation)

Dimensions  $424 \times 376 \times 95.5$  mm (w/h/d)  
( $16 \frac{3}{4} \times 14 \frac{7}{8} \times 3 \frac{7}{8}$  inches) (not  
including the stand)  
 $424 \times 419 \times 258$  mm (w/h/d)  
( $16 \frac{3}{4} \times 16 \frac{1}{2} \times 10 \frac{1}{4}$  inches)  
(including the stand)

Mass  
Approx. 8 kg (17 lb 9 oz)

Supplied accessories  
Optical mouse PCS-RMU1 (1)  
AC adaptor VGP-AC19V15 (1)  
Power cord (1)  
CD-ROM (1)  
Quick Start Guide (1)  
Warranty booklet (1)

## VGP-AC19V15 AC Adaptor

Power requirements  
 $100$  to  $240$  V AC, 50/60 Hz,  
1.6 A to 0.7 A

Output 19.5 V DC, 6.2 A

Operating temperature  
 $5^\circ\text{C}$  to  $35^\circ\text{C}$  ( $41^\circ\text{F}$  to  $94^\circ\text{F}$ )

Operating humidity  
20% to 80%

Storage temperature  
 $-20^\circ\text{C}$  to  $+60^\circ\text{C}$  ( $-4^\circ\text{F}$  to  $+140^\circ\text{F}$ )

Storage humidity  
20% to 80% (no condensation)

Dimensions  $155 \times 67 \times 36.5$  mm (w/h/d)  
( $6 \frac{1}{8} \times 2 \frac{3}{4} \times 1 \frac{7}{16}$  inches)  
(not including the projected parts)

Mass  
Approx. 550 g (1 lb 3 oz)

## PCS-A1 Microphone (Optional)

Bandwidth 13 kHz

Directional characteristic  
Omnidirectional

Dimensions  $74 \times 16 \times 93$  mm (w/h/d)  
( $3 \times \frac{21}{32} \times 3 \frac{3}{4}$  inches)

Mass  
Approx. 170 g (6 oz)

Power  
Plug in power

Cable length 8 m (26 ft 3 in)

## PCSA-A3 Microphone (Optional)

Bandwidth	13 kHz
Directional characteristic	Unidirectional
Dimension	68 × 16 × 96 mm (w/h/d) (2 3/4 × 21/32 × 3 7/8 inches)
Mass	Approx. 200 g (7 oz)
Power	Plug in power
Cable length	8 m (26 ft 3 in)

## PCSA-DSM1 Data Solution Module (Optional)

Power consumption	20 W max.
Operating temperature	5 °C to 35 °C (41 °F to 94 °F)
Operating humidity	20% to 80%
Storage temperature	-20 °C to +60 °C (-4 °F to +140 °F)
Storage humidity	20% to 80% (no condensation)
Dimensions	107 × 250 × 34 mm (w/h/d) (4 1/4 × 9 7/8 × 1 3/8 inches) (not including the projected parts)
Mass	Approx. 550 g (1 lb 3 oz)
Supplied accessories	Quick Start Guide (1) Warranty booklet (1)

## PCSA-SP1 SIP Software (Optional)

Supplied accessories	Serial Number seal (1) Operating Instructions (1)
----------------------	--

Design and specifications are subject to change without notice.

This product uses Ricoh bitmap fonts produced and marketed by Ricoh Co., Ltd.

### Note

Always verify that the unit is operating properly before use. SONY WILL NOT BE LIABLE FOR DAMAGES OF ANY KIND INCLUDING, BUT NOT LIMITED TO, COMPENSATION OR REIMBURSEMENT ON ACCOUNT OF THE LOSS OF PRESENT OR PROSPECTIVE PROFITS DUE TO FAILURE OF THIS UNIT, EITHER DURING THE WARRANTY PERIOD OR AFTER EXPIRATION OF THE WARRANTY, OR FOR ANY OTHER REASON WHATSOEVER.

## Acceptable RGB Input/Output Signals

### PCS-TL33 Video Communication System (RGB IN)

Picture element	Signal format	fH (kHz)	fV (Hz)	Dot clock (MHz)	Sync
640 × 480	VGA mode	31.469	59.94	25.17	H-neg V-neg
	Macintosh 13"	35	66.667	30.24	H-neg V-neg
	VGA VESA 72 Hz	37.861	72.809	31.5	H-neg V-neg
	VGA VESA 75 Hz	37.5	75	31.5	H-neg V-neg
	VGA VESA 85 Hz	43.269	85.008	36	H-neg V-neg
800 × 600	SVGA VESA 56 Hz	35.156	56.25	36	H-pos V-pos
	SVGA VESA 60 Hz	37.879	60.317	40	H-pos V-pos
	SVGA VESA 72 Hz	48.077	72.188	50	H-pos V-pos
	SVGA VESA 75 Hz	46.875	75	49.5	H-pos V-pos
	SVGA VESA 85 Hz	53.674	85.061	56.25	H-pos V-pos
1024 × 768	XGA VESA 60 Hz	48.363	60.004	65	H-neg V-neg
	XGA VESA 70 Hz	56.476	70.069	75	H-neg V-neg
	XGA VESA 75 Hz	60.023	75.029	78.75	H-pos V-pos
1280 × 768	WXGA VESA 60 Hz*	47.693	59.992	80.12	H-neg V-pos

\* Cannot be transmitted by the PCSA-DSM1 Data Solution Module.

### PCSA-DSM1 Data Solution Module (RGB IN) (Connector located on PCS-TL33)

Picture element	Signal format	fH (kHz)	fV (Hz)	Dot clock (MHz)	Sync
640 × 480	VGA mode	31.469	59.94	25.17	H-neg V-neg
	Macintosh 13"	35	66.667	30.24	H-neg V-neg
	VGA VESA 72 Hz	37.861	72.809	31.5	H-neg V-neg
	VGA VESA 75 Hz	37.5	75	31.5	H-neg V-neg
	VGA VESA 85 Hz	43.269	85.008	36	H-neg V-neg
800 × 600	SVGA VESA 56 Hz	35.156	56.25	36	H-pos V-pos
	SVGA VESA 60 Hz	37.879	60.317	40	H-pos V-pos
	SVGA VESA 72 Hz	48.077	72.188	50	H-pos V-pos
	SVGA VESA 75 Hz	46.875	75	49.5	H-pos V-pos
	SVGA VESA 85 Hz	53.674	85.061	56.25	H-pos V-pos
1024 × 768	XGA VESA 60 Hz	48.363	60.004	65	H-neg V-neg
	XGA VESA 70 Hz	56.476	70.069	75	H-neg V-neg
	XGA VESA 75 Hz	60.023	75.029	78.75	H-pos V-pos

### PCSA-DSM1 Data Solution Module (RGB OUT)

Picture element	Signal format	fH (kHz)	fV (Hz)	Dot clock (MHz)	Sync
1024 × 768	XGA VESA 60 Hz	48.363	60.004	65	H-neg V-neg

\* While the picture input from the RGB IN connector is transmitted, the picture of the input signal format (VGA, SVGA or XGA) is output from this connector.

## Pin Assignment

### 100BASE-TX/10BASE-T port



Modular port

Pin	Signal	Description
1	TPOPTX+	Transmit+
2	TPONTX-	Transmit-
3	TPIPRX+	Receive+
4	NC	-
5	NC	-
6	TPINRX-	Receive-
7	NC	-
8	NC	-

### RGB IN connector

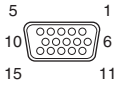

Mini D-sub 15-pin (female)

Pin	Signal	Description
1	RED	R (red)
2	GREEN	G (green)
3	BLUE	B (blue)
4	NC	-
5	GDN	Ground
6	RED. GND	R (red) signal ground
7	GREEN. GND	G (green) signal ground
8	BLUE. GND	B (blue) signal ground
9	NC	-
10	SYNC. GND	Sync signal ground
11	NC	-
12	NC	-
13	HSYNC	Horizontal sync
14	VSYSN	Vertical sync
15	NC	-

### RS-232C connector

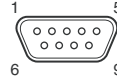

D-sub 9-pin (male)

Pin	Signal	Description
1	NC	-
2	RD	Receive
3	TD	Transmit
4	NC	-
5	GND	Ground
6	NC	-
7	NC	-
8	NC	-
9	NC	-

### Mouse connector



Mouse connector

Pin	Signal	Description
1	Vbus	Power
2	-Data (D-)	Transmit/receive data-
3	+Data (D+)	Transmit/receive data+
4	GND	Ground

### PC connector



PC connector

Pin	Signal	Description
1	Vbus	Power
2	-Data (D-)	Transmit/receive data-
3	+Data (D+)	Transmit/receive data+
4	GND	Ground

## Pin Assignment on Optional Board Connectors

### RGB OUT connector (PCSA-DSM1)

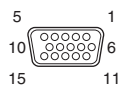

Mini D-sub 15-pin (female)

Pin	Signal	Description
1	RED	R (red)
2	GREEN	G (green)
3	BLUE	B (blue)
4	NC	-
5	GND	Ground
6	RED. GND	R (red) signal ground
7	GREEN. GND	G (green) signal ground
8	BLUE. GND	B (blue) signal ground
9	NC	-
10	SYNC. GND	Sync signal ground
11	NC	-
12	NC	-
13	HSYNC	Horizontal sync
14	VSYNC	Vertical sync
15	NC	-

## List of Port Numbers Used on the PCS-TL33

### When connecting one-to-one (Default)

When “Port Number Used” is set to “Default” in the Administrator Setup menu, the PCS-TL33 uses the following port numbers.

Signal	Port number
RAS (PCS-TL33)	1719 (using GateKeeper)
RAS (GateKeeper)	1718 or 1719 (using GateKeeper)
Q.931 (dial)	Any number from 2253 to 2255
Q.931 (answer)	1720
H.245	Any number from 2253 to 2255
Audio RTP	49152
Audio RTCP	49153
Video RTP	49154
Video RTCP	49155

Signal	Port number
FECC RTP	49156
FECC RTCP	49157
Data conference RTP	49158
Data conference RTCP	49159

### When connecting one-to-one (Custom: TCP Port Number 3000 and UDP Port Number 3100)

When “Port Number Used” is set to “Custom” in the Administrator Setup menu, the PCS-TL33 uses the port numbers defined by the values entered in “TCP Port Number” and “UDP Port Number”.

For example, when “TCP Port Number” is set to “3000” and “UDP Port Number” is set to “3100”, the PCS-TL33 uses the following port numbers.

Signal	Port number
RAS (PCS-TL33)	1719 (using GateKeeper)
RAS (GateKeeper)	1718 or 1719 (using GateKeeper)
Q.931 (dial)	Any number from 3000 to 3002
Q.931 (answer)	1720
H.245	Any number from 3000 to 3002
Audio RTP	3100
Audio RTCP	3101
Video RTP	3102
Video RTCP	3103
FECC RTP	3104
FECC RTCP	3105
Data conference RTP	3106
Data conference RTCP	3107

### Note

For the RTP and RTCP signals, ranges higher than the ones listed above may be used when ports are unable to be used properly.

# Videoconferencing Room Layout

## Layout example

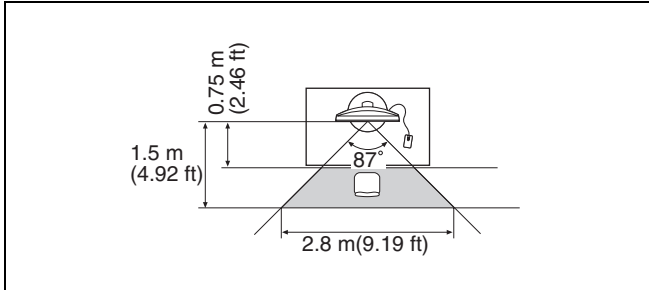

## Camera Range

■ represents the shooting area of the camera when the zoom has been extended fully. Use the measurements below as a guide for the layout of your videoconference room.

### Top view (horizontal range at maximum zoom-out)

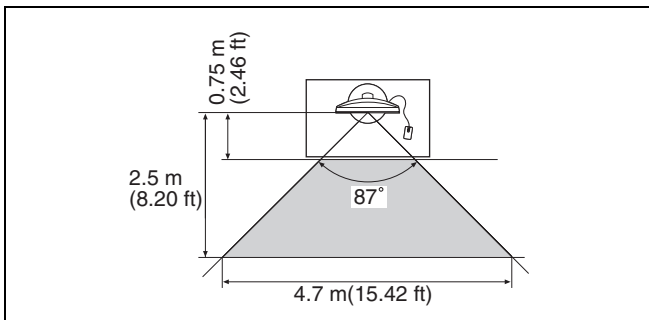

### Side view (vertical range at maximum zoom-out)

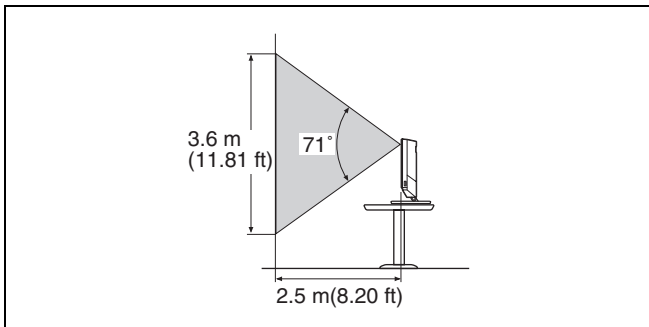

## Layout Considerations

- Avoid having large, moving objects, especially people, behind the participants, as the quality of the picture transmitted to the remote party will deteriorate.
- Do not seat participants in front of a wall with fine stripe patterns.
- Choose a room where echo will not occur.
- Do not install the system near noise sources such as air conditioners or copy machines.
- Avoid placing the system in a room where there are the speakers used for an in-house broadcasting system.

## Lighting Considerations

Do not point the camera toward a window where sunlight comes in as back lighting may decrease the contrast. If it is necessary, cover the window with a thick curtain.

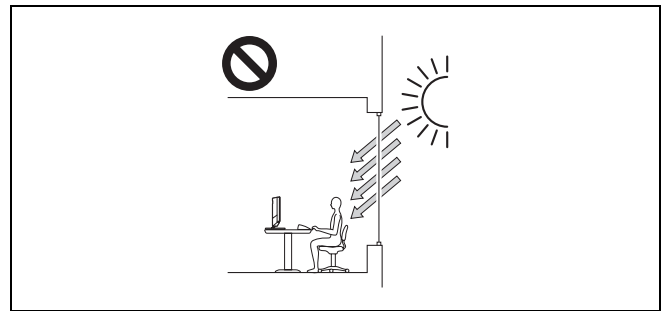

Adjust room lighting so that it falls on the participants. Avoid direct light on the display. Light intensity on faces should be about 300 lux or more.

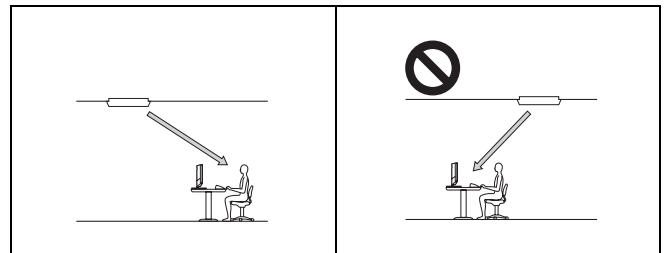



---

# Glossary

## **CIF**

An abbreviation for Common Intermediate Format. This format allows communication between different color systems (NTSC and PAL).  
352 pixels × 288 lines

## **Codec**

An abbreviation for Coder-Decoder. An integrated device of a coder that converts an analog audio/video signal to a digital data stream and compresses it, and a decoder for expanding to restore the original analog signal.

## **DHCP**

An abbreviation for Dynamic Host Configuration Protocol. Manages IP addresses in the network.

## **DNS**

An abbreviation for Domain Name System. Defines the domain name system server.

## **Echo Cancellor**

Device to eliminate echo that occurs when transmitting audio.

## **Frame rate**

The number of frames which can be encoded/decoded in one second.

## **G.711**

Audio encoding/decoding format recommended by the ITU-T. A phone bandwidth audio signal is converted to a digital signal with a data rate of 64 kbps. It can be transmitted with a data rate of 56 kbps.

## **G.722**

Audio encoding/decoding format recommended by the ITU-T. A 7-kHz bandwidth audio signal is converted to a digital signal with a data rate of 48 kbps, 56 kbps or 64 kbps.

## **G.728**

Audio encoding/decoding format recommended by the ITU-T. A phone bandwidth audio signal is converted to a digital signal with a data rate of 16 kbps.

## **G.729**

Audio encoding/decoding format recommended by the ITU-T. A phone bandwidth audio signal is converted to a digital signal with the data rate of 8 kbps.

## **Gatekeeper**

Controls the access of H.323 videoconference devices on a network. Administers the zone, access limitation, audio/video bandwidth, and alias etc.

## **H.225.0**

Frame structure for a 64 to 1920 kbps channel in audiovisual teleservices.

## **H.239**

ITU-T standard for sharing data and presentations with video. This supports dual streaming, enabling endpoints to receive and transmit video and presentation data simultaneously.

## **H.261**

Video codec for audio/visual services as p × 64 kbps. Videoconferencing standard that defines a video coding algorithm, picture format and error correcting technology for communication between different manufacturers' video codecs.

## **H.263**

A video coding algorithm based on the H.261 standard. This format enables communication via a lower bit rate.

## **H.263+**

Video encoding/decoding format based on the H.263 standard, added by the Annex I to T (I, J, K ..... T), that allows enhanced picture quality and error resistance. Normally, this format is a profile used with a combination of some of the Annex for H.263/H.263+.

## **H.264**

A video coding algorithm standardized by the ITU-T in May 2003. This format realizes high-quality picture via a lower bit rate. It provides an equal picture quality via half as low bit rate as the H.263 format. The H.264 format is also called as MPEG4 Advanced Video Coding (AVC).

## **H.323**

This enables communications on the non-QOS (Quality of Service) LAN.

## **HMLP**

See "MLP".

## **Lip synchronization**

A function that synchronizes sound with motion. Sound processing is much faster than motion processing, thus sound and motion sometimes get out of step with each other.

## **MCU**

An abbreviation for Multipoint Control Unit. When connecting a MCU, a multipoint videoconference can be held.

**MLP**

Data communication is also available during communication of video/audio signals between the videoconferencing systems. The MLP or HMLP is a protocol for data communication such as NetMeeting. Using the HMLP protocol allows faster data transmission.

**MPEG4**

A video coding algorithm recommended by the ISO/IEC based on the H.263+ standard. Adding some tools provides some improvement of picture quality compared with the H.263+ standard. The MPEG4 format is commonly used for personal computers, cellular phones, etc.

**P in P**

An abbreviation for "Picture in Picture." This is a function which allows you to monitor your own party on a small window on your TV monitor.

**QCIF**

An abbreviation for Quarter CIF. The number of pixels is a quarter than one of CIF format.  
176 pixels × 144 lines

**SNMP**

An abbreviation for Simple Network Management Protocol. This protocol is for management information between the management station and the managed terminals. This enables the monitoring of Sony Video Communication Systems.

**SPID**

An abbreviation for Service Profile ID.

**TOS**

Inputting the information data in the TOS field of the IP address allows the communication system to judge the packet transmission priority, etc. It also enables change of path according to the types of service (Delay or Size).

# Menu Configuration

The menus of the camera are configured as described below.

For detailed information, see pages in parentheses. The initial settings of each item are bolded.

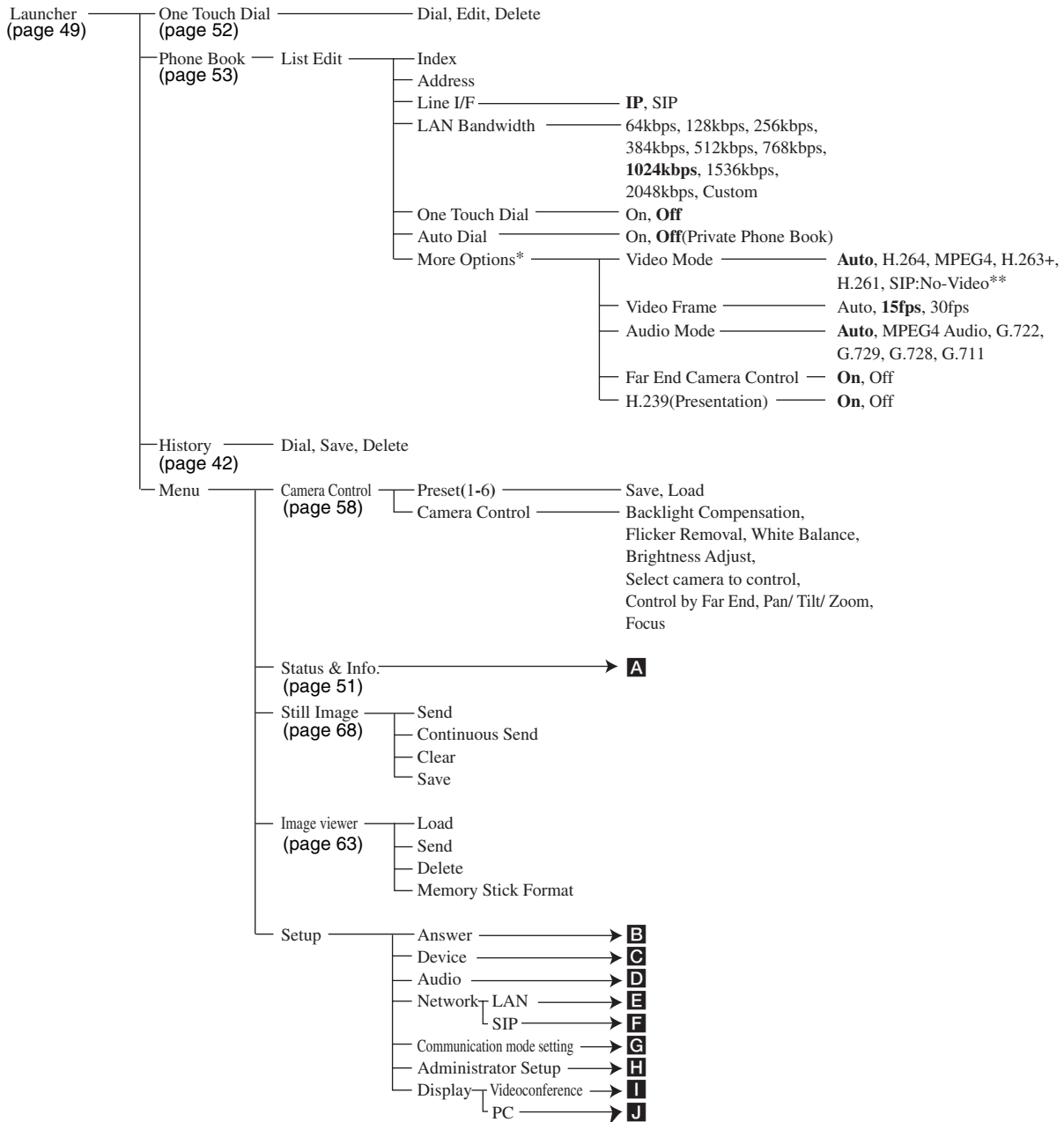

\* Available only when "More Options Enable" is set to "On" in the Dial settings of the Communication Mode menu.  
 \*\* Available only when the optional PCSA-SP1 SIP software is installed.

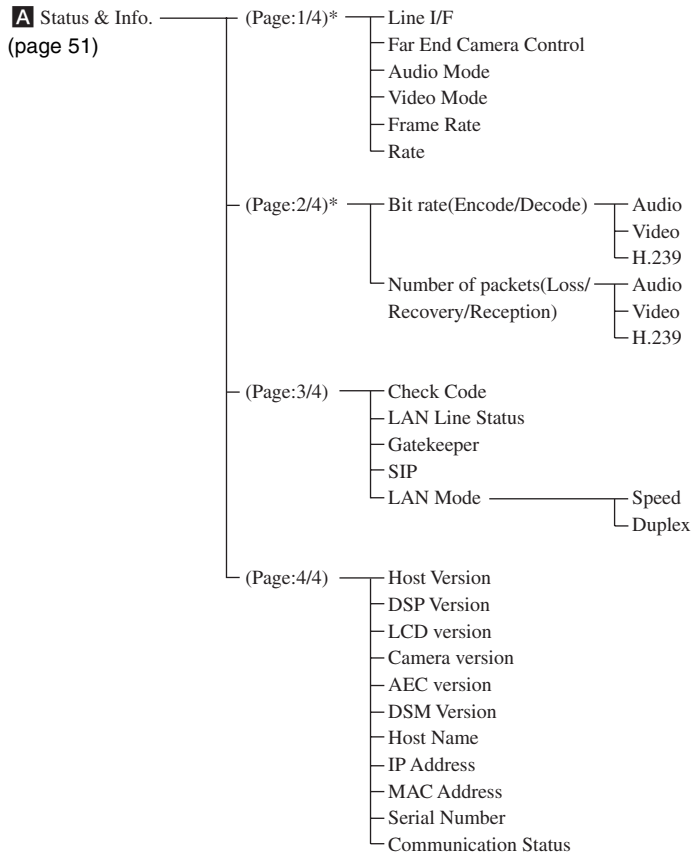

\* Does not display if no communications have been held since the power was turned on.

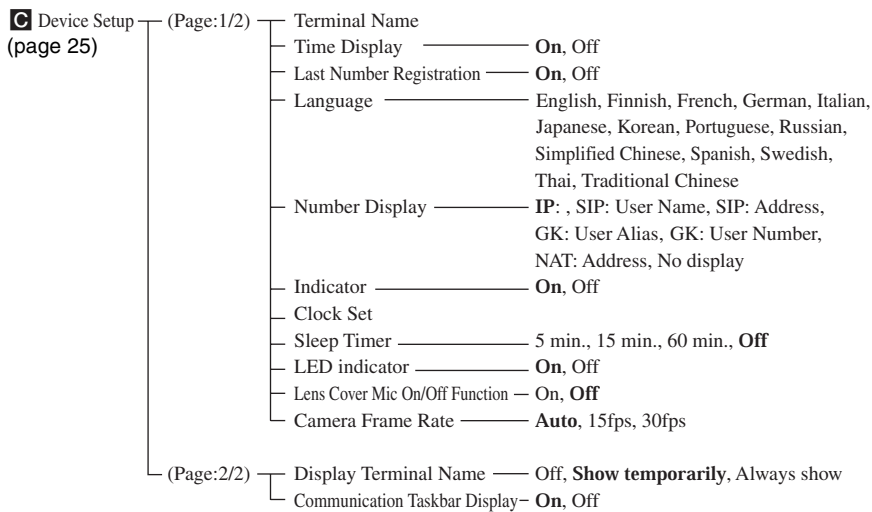
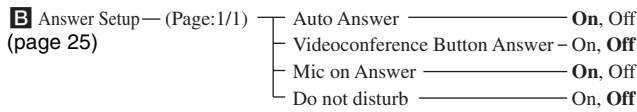

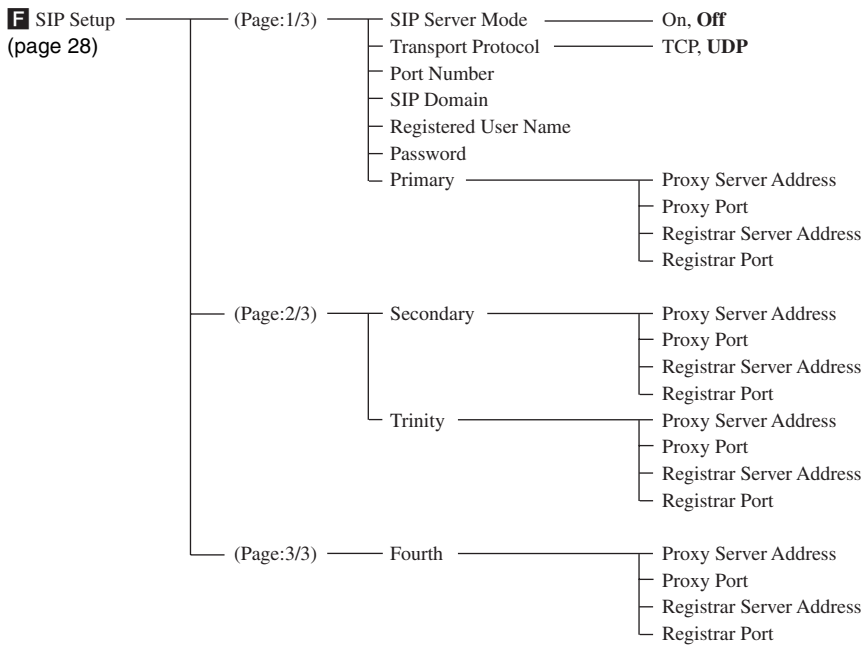
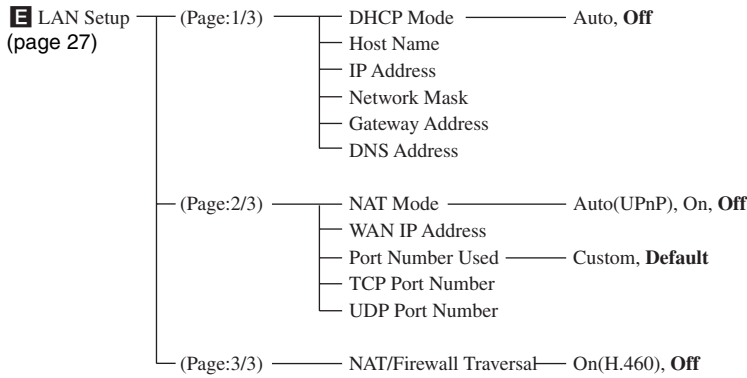
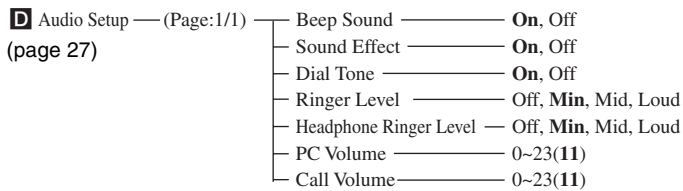

**C** Communication Mode  
(page 29)

Dial (Page:1/3)	Video Mode	Auto, H.264, MPEG4, H.263+, H.261, SIP:No-Video*
	Video Frame	Auto, <b>15fps</b> , 30fps
	Audio Mode	Auto, MPEG4 Audio, G.722, G.729, G.728, G.711
	LAN Bandwidth	64kbps, 128kbps, 256kbps, 384kbps, 512kbps, 768kbps, <b>1024kbps</b> , 1536kbps, 2048kbps, User Input
	Input LAN Bandwidth	
	Far End Camera Control	<b>On</b> , Off
	H.239(Presentation)	<b>On</b> , Off
	Line I/F	<b>IP</b> , SIP
	Lip Sync	On, <b>Off</b>
	More Options	On, <b>Off</b>
Answer (Page:2/3)	Video Mode	Auto, H.264, MPEG4, H.263+, H.261, SIP: No-Video*
	Video Frame	Auto, <b>15fps</b> , 30fps
	Audio Mode	Auto, MPEG4 Audio, G.722, G.729, G.728, G.711
	LAN Bandwidth	64kbps, 128kbps, 256kbps, 384kbps, 512kbps, 768kbps, <b>1024kbps</b> , 1536kbps, 2048kbps, User Input
	Input LAN Bandwidth	
Encryption via LAN (Page:3/3)	Encryption via LAN	On, <b>Off</b>
	Encryption Protocol	<b>Standard</b> , Proprietary
	Connectivity Prioritization	<b>Connection</b> , Encryption
	Encryption Password	

\* Available only when the optional PCSA-SP1 SIP software is installed.

**H** Administrator Setup  
(page 32)

- (Page:1/11)
  - Administrator Password
  - Phone Book Modification Password
  - Remote Access Password
  - Web Monitor  On, **Off**
  - Web Access  On, **Off**
  - Save Phone Book
  - Load Phone Book
  - Create Private Phone Book
  - Delete Private Phone Book
  - Copy to Private Phone Book
  - Auto Dialing  On, **Off**
- (Page:2/11)
  - Gatekeeper Mode  Auto, On, **Off**
  - Gatekeeper Address
  - User Alias
  - User Number
- (Page:3/11)
  - SNMP Mode  On, **Off**
  - Trap Destination
  - Community
  - Description
  - Location
  - Contact
- (Page:4/11)
  - Packet Resend Request  On, **Off**
  - Adaptive Rate Control  On, **Off**
  - LAN Mode  **Auto Negotiation**,  
100Mbps Full Duplex,  
100Mbps Half Duplex,  
10Mbps Full Duplex,  
10Mbps Half Duplex
- (Page:5-8/11)
  - TOS  IP Precedence, Diffserve, **Off**
  - IP Precedence
  - Low Delay  On, **Off**
  - High Throughput  On, **Off**
  - High Reliability  On, **Off**
  - Minimum Cost  On, **Off**
  - Diffserve
- (Page:9/11)
  - PPPoE  On, **Off**
  - PPPoE User Name
  - PPPoE Password
  - Fixed IP for PPPoE  On, **Off**
  - Fixed IP Address for PPPoE
  - PPPoE DNS  **Obtain Automatically**, Specify
  - Primary DNS
  - Secondary DNS
- (Page:10/11)
  - Capture remote image  On, **Off**
  - Ringer with headphones  On, **Off**
  - Display DTMF button  On, **Off**
  - Auto Restore  On, **Off**
  - Restore factory defaults
  - Save Application Software
  - Update software
  - Memory Stick Format
  - Save Setup
  - Load Setup
  - Function Extension Command
- (Page:11/11)
  - Shared Phone Book  On, **Off**
  - SPB Mode  On, **Off**
  - SPB Server Address
  - SPB Auto Registration  On, **Off**
  - SPB Server Password

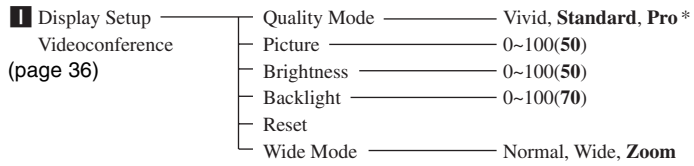

\* When Japanese is selected in the Initial Setup Wizard, “Standard” is the default setting. When any other language is selected, “Pro” is the default setting.

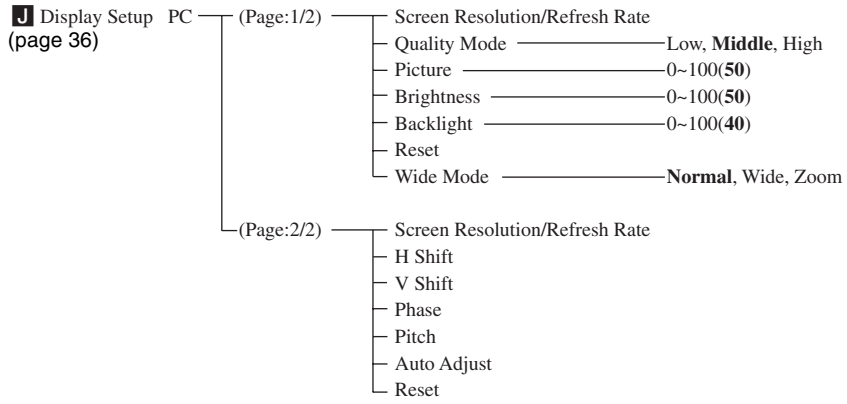



<http://www.sony.net/>

Sony Corporation